

V1.07

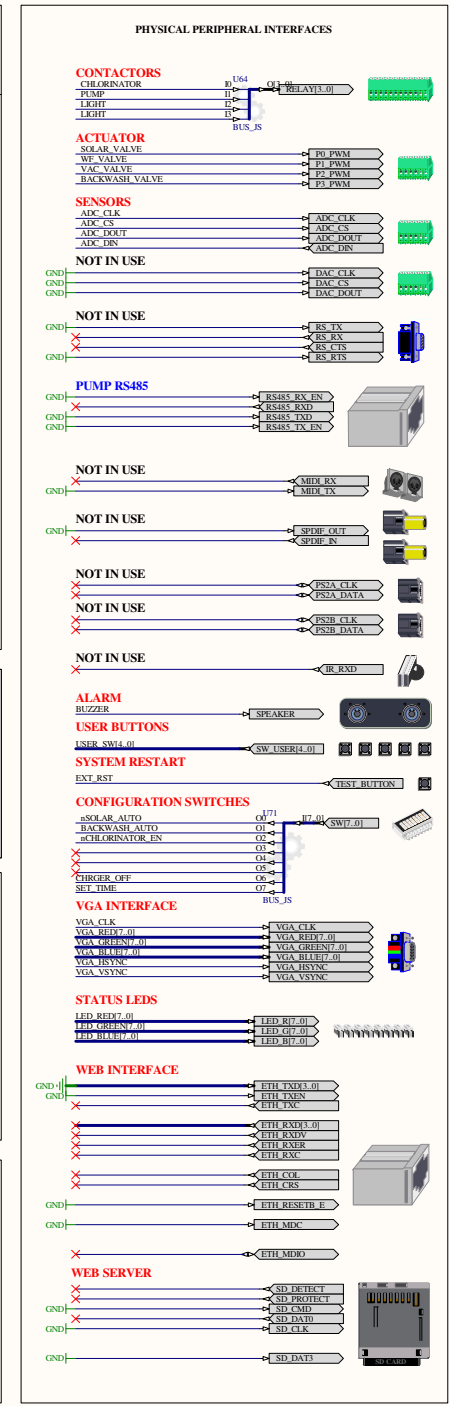

CHARGER = ENABLED
 CLOCK = 1
 RESISTANCE = 2K

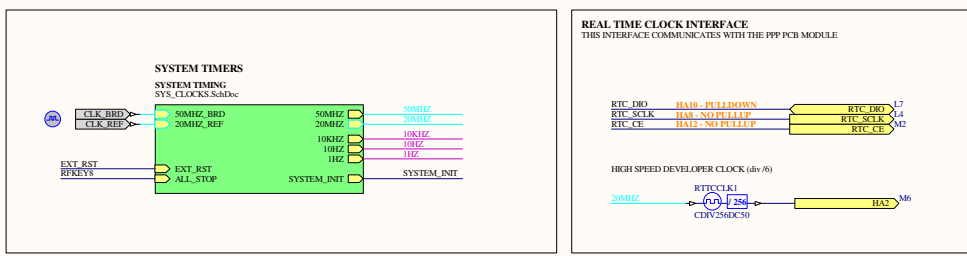
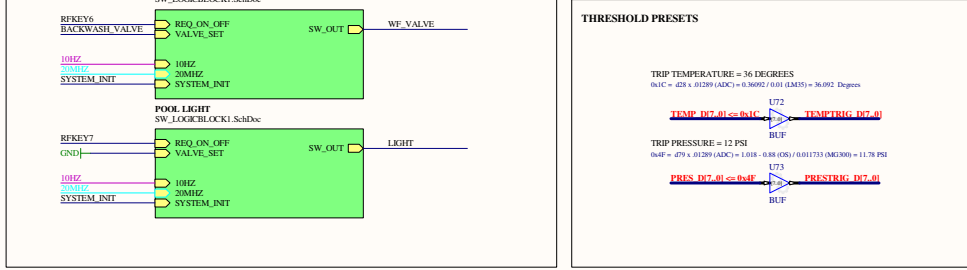
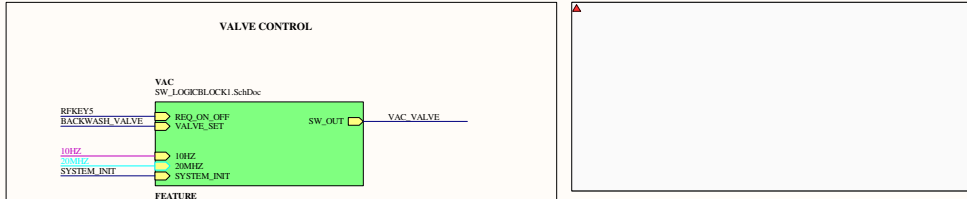
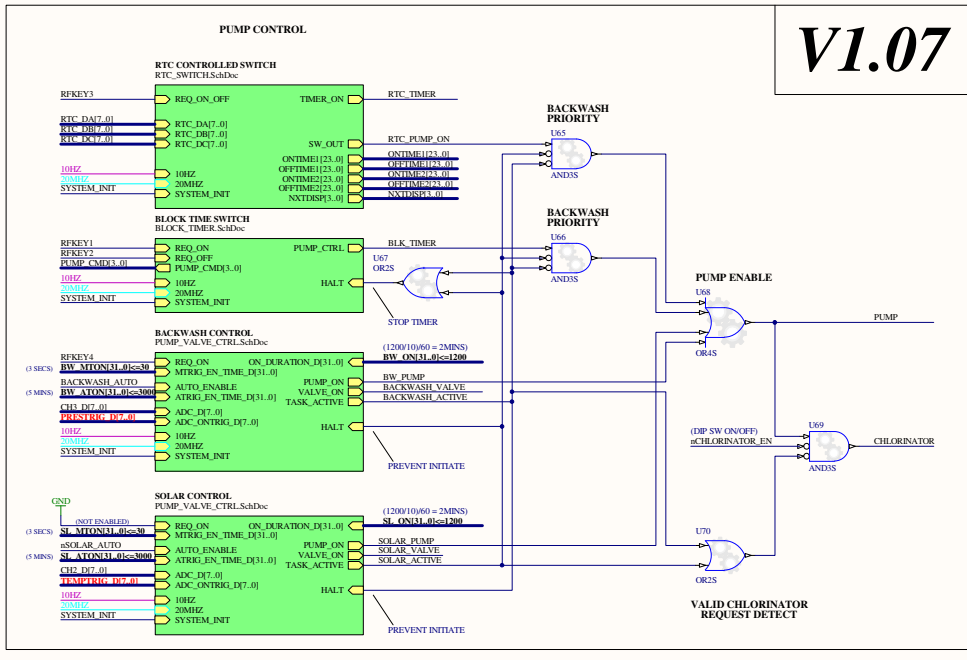
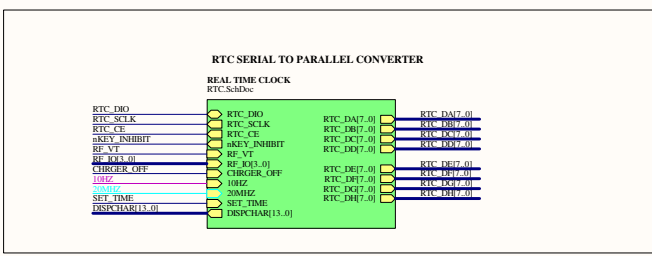
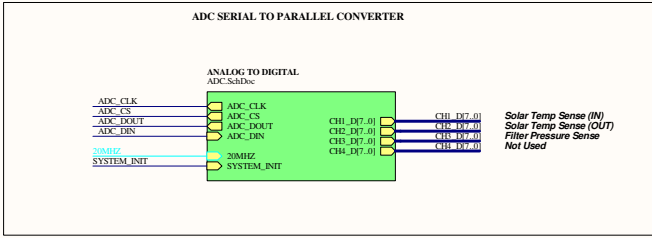
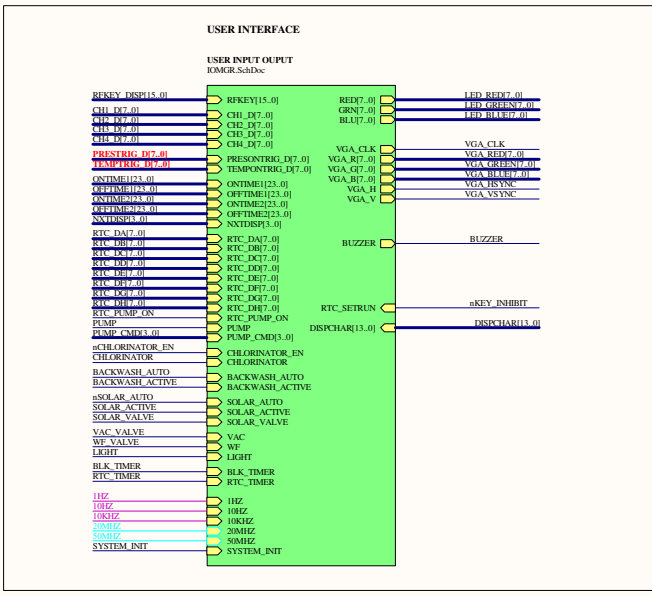
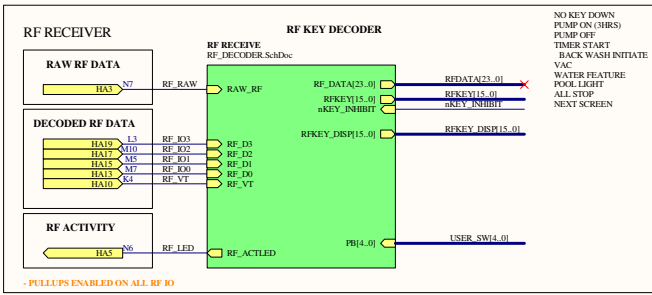
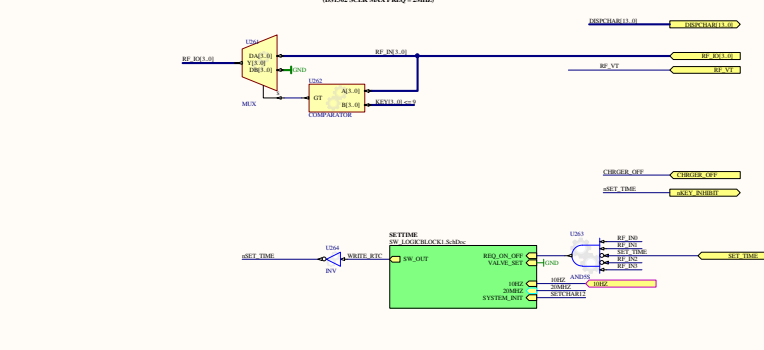
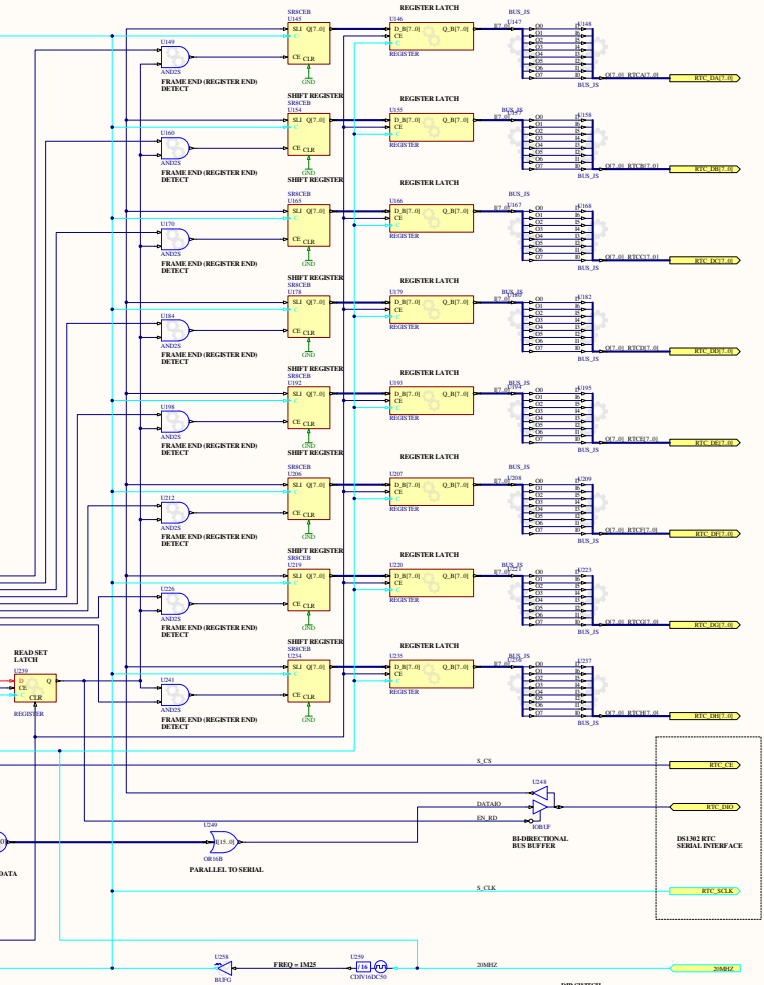
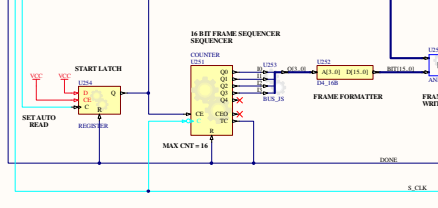
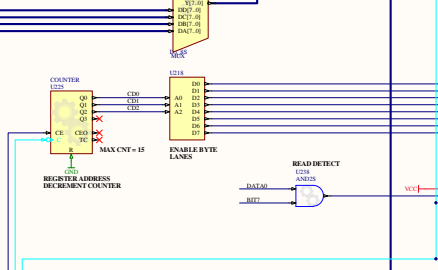
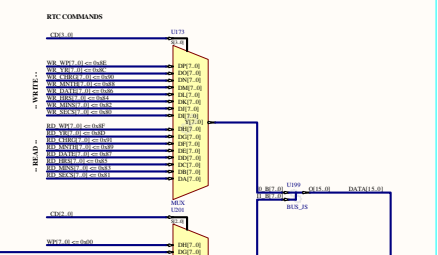
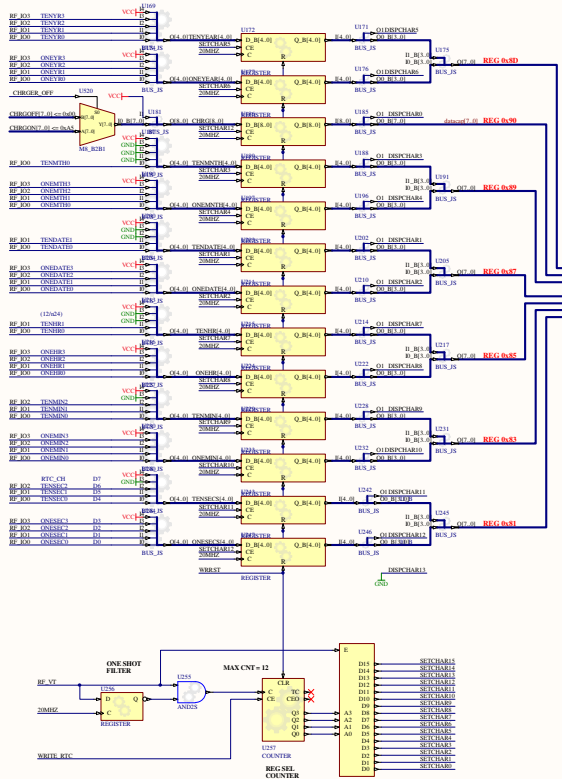

RTC

READ	WRITE	BIT 7	BIT 6	BIT 5	BIT 4	BIT 3	BIT 2	BIT 1	BIT 0	RANGE
8th	8th	CH	10	Seconds	Seconds	00-59				
9th	8th	12/24	0	10	Minutes	Minutes	00-59			
10th	8th	0	0	10	Hour	Hour	1-12/0-23			
11th	8th	0	0	0	10	Date	1-31			
12th	8th	0	0	0	10	Month	1-12			
13th	8th	0	0	0	0	Year	00-99			
14th	8th	VP	0	0	0	0	0			
15th	8th	TCS	TCS	TCS	TCS	DS	DS	RS	RS	

CLOCK BURST

Bit	BEH	BEH
0	0	0
1	0	0
2	0	0
3	0	0
4	0	0
5	0	0
6	0	0
7	0	0
8	0	0
9	0	0
10	0	0
11	0	0
12	0	0
13	0	0
14	0	0
15	0	0

RAM

Bit	CH	CH	00-FH
0	0	0	00-FH
1	0	0	00-FH
2	0	0	00-FH
3	0	0	00-FH
4	0	0	00-FH
5	0	0	00-FH
6	0	0	00-FH
7	0	0	00-FH
8	0	0	00-FH
9	0	0	00-FH
10	0	0	00-FH
11	0	0	00-FH
12	0	0	00-FH
13	0	0	00-FH
14	0	0	00-FH
15	0	0	00-FH

WRITE REGISTER: 8 BIT FRAME END AND REGISTER END DETECT

GLOBAL CLOCK SET

FREQ = 1MHz

SCLK SET TO 12MHz

DS12C88 MAX FREQ = 2MHz

BIPO SWITCH ACTIVE HIGH

SETTIME

SW OUT

SETTIME

SETTIME

SETTIME

SETTIME

SETTIME

SETTIME

SETTIME

SETTIME

SETTIME

SETTIME

SETTIME

SETTIME

SETTIME

SETTIME

SETTIME

SETTIME

SETTIME

SETTIME

SETTIME

SETTIME

SETTIME

SETTIME

SETTIME

SETTIME

4-TO-16 RF NIBBLE BINARY DECODER

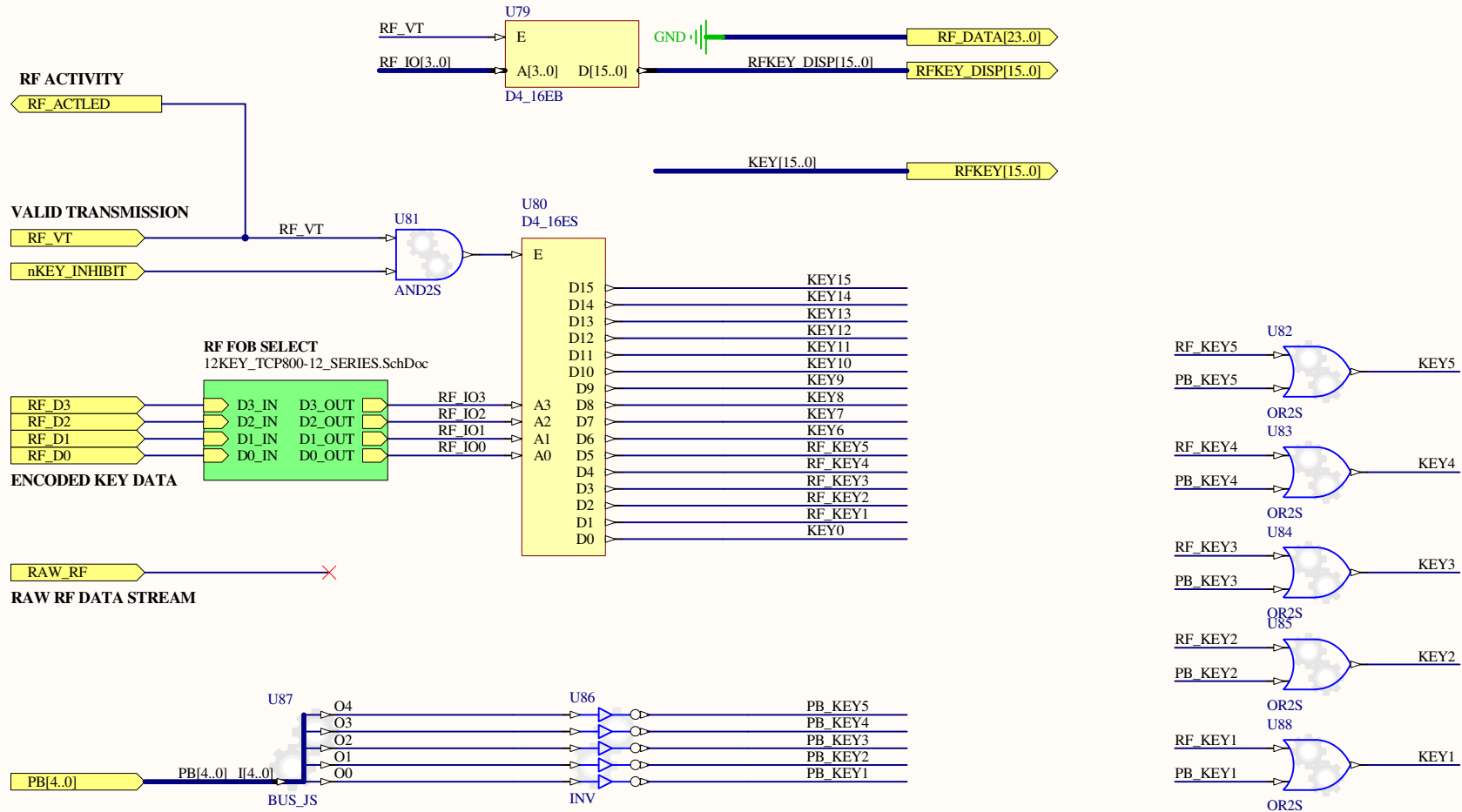

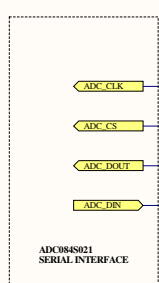

NOTE:
 Channel 3 (ADC2 on NB3K)
 has a 220R current resistor
 installed to ground for the
 4-20mA pressure sensor

8 bit @ 200Ksps
 Maximum sample rate (nyquist) : 100kHz
 0.012890625v = 1 bit (3V3 ref) resolution
 0x01 = 0.012890625v 0xFF = 3.287109375v

Timing Diagrams

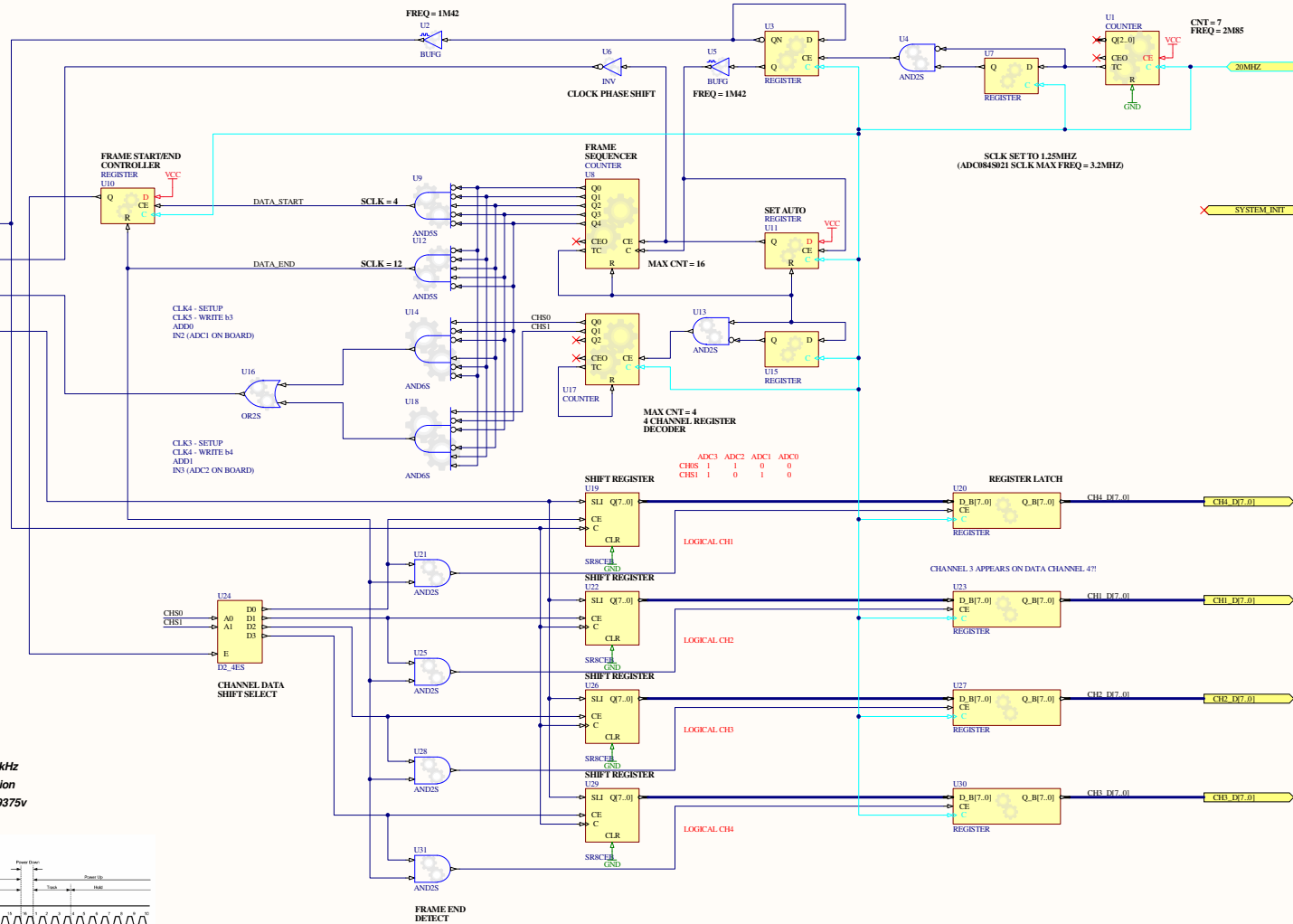
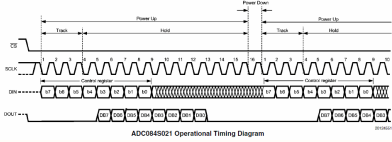

SCLK SET TO 1.25MHZ
 (ADC084S021 SCLK MAX FREQ = 3.2MHZ)

ADC3 ADC2 ADC1 ADC0
 CHS3 1 1 0 0
 CHS1 1 0 1 0

CHANNEL 3 APPEARS ON DATA CHANNEL 4!

FRAME END DETECT

ADC084S021 Operational Timing Diagram

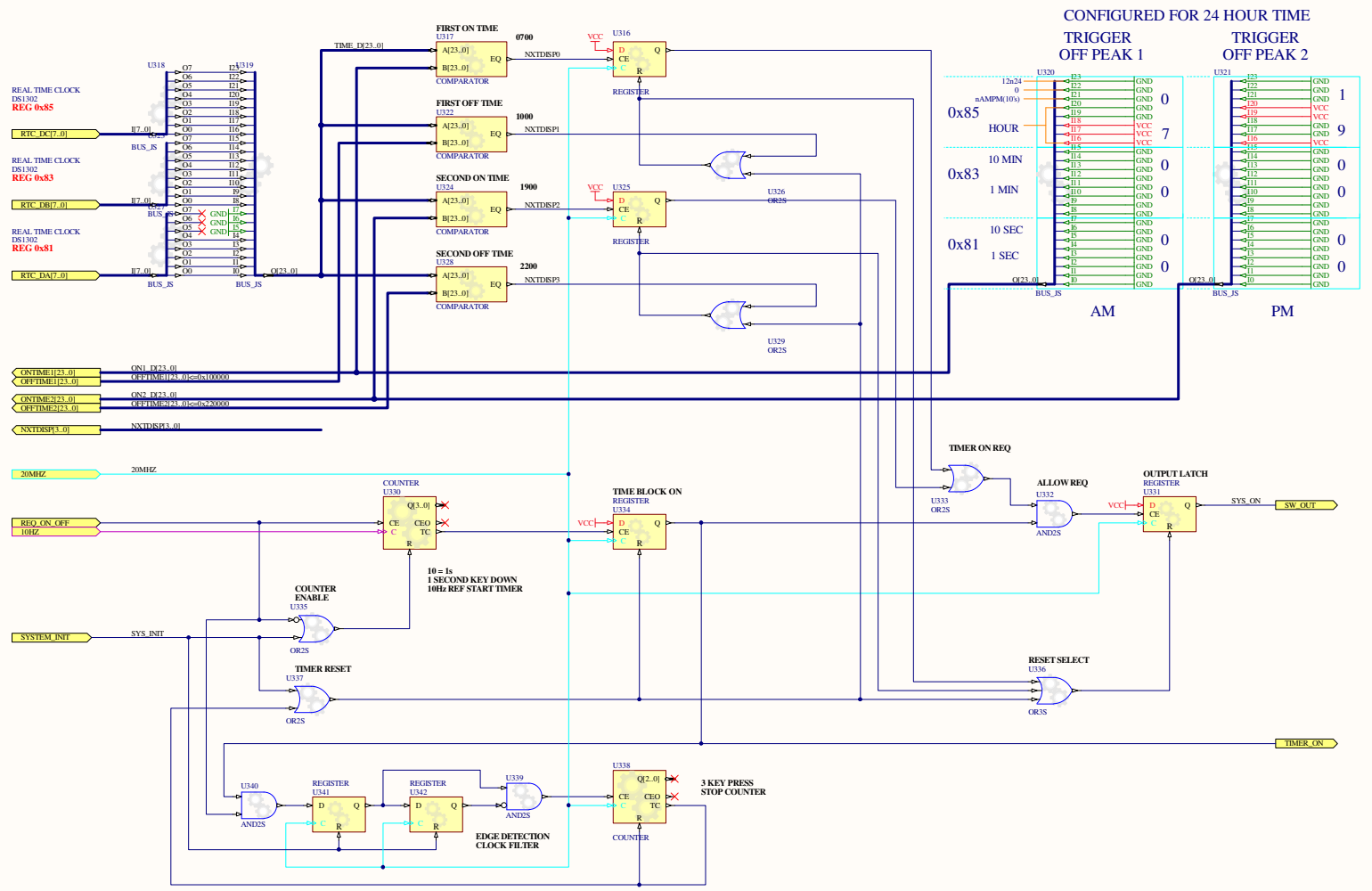

Solar Temp Sense (IN)
Solar Temp Sense (OUT)
Filter Pressure Sense
Not Used

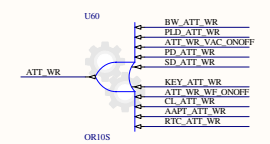
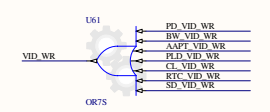
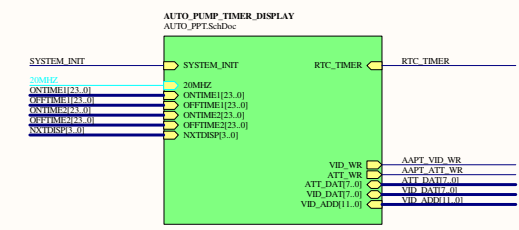
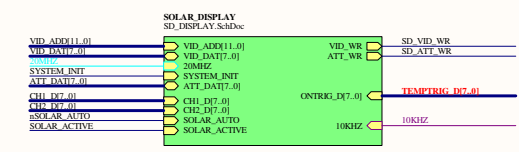
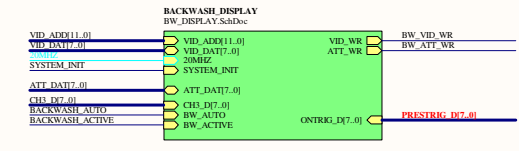
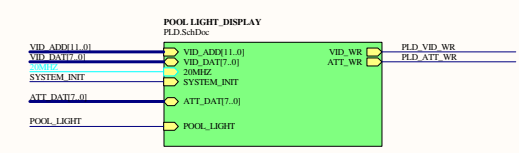
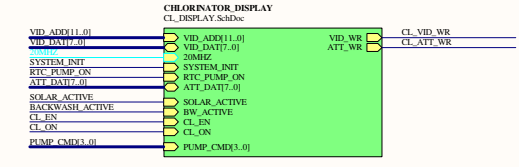
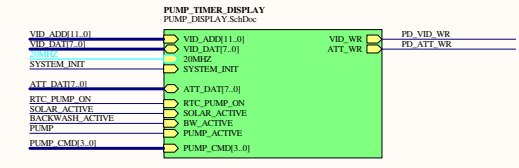
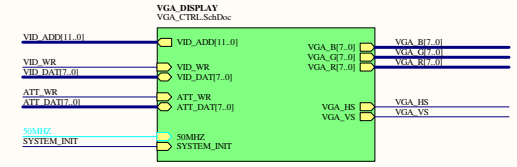
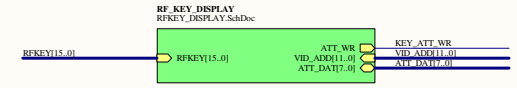
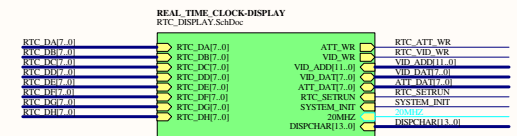
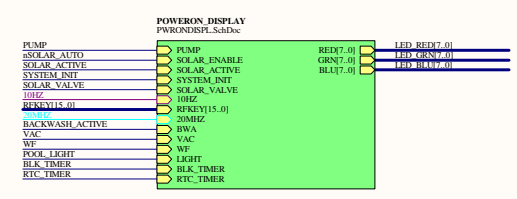
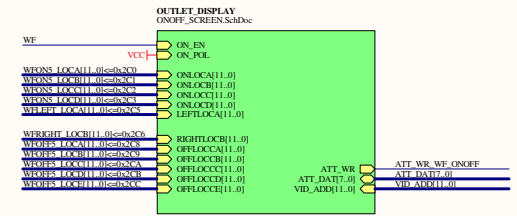
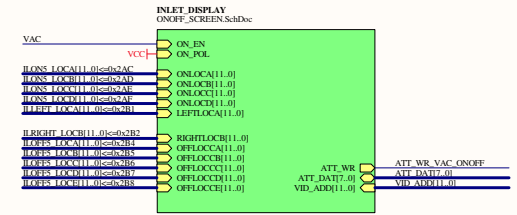
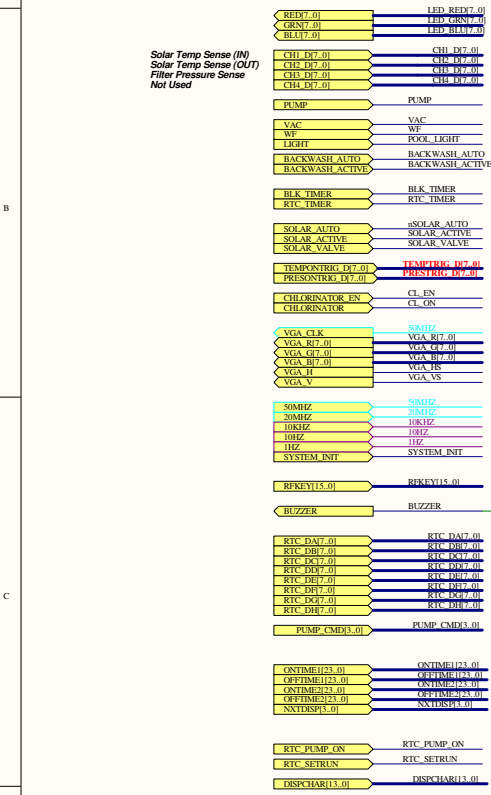

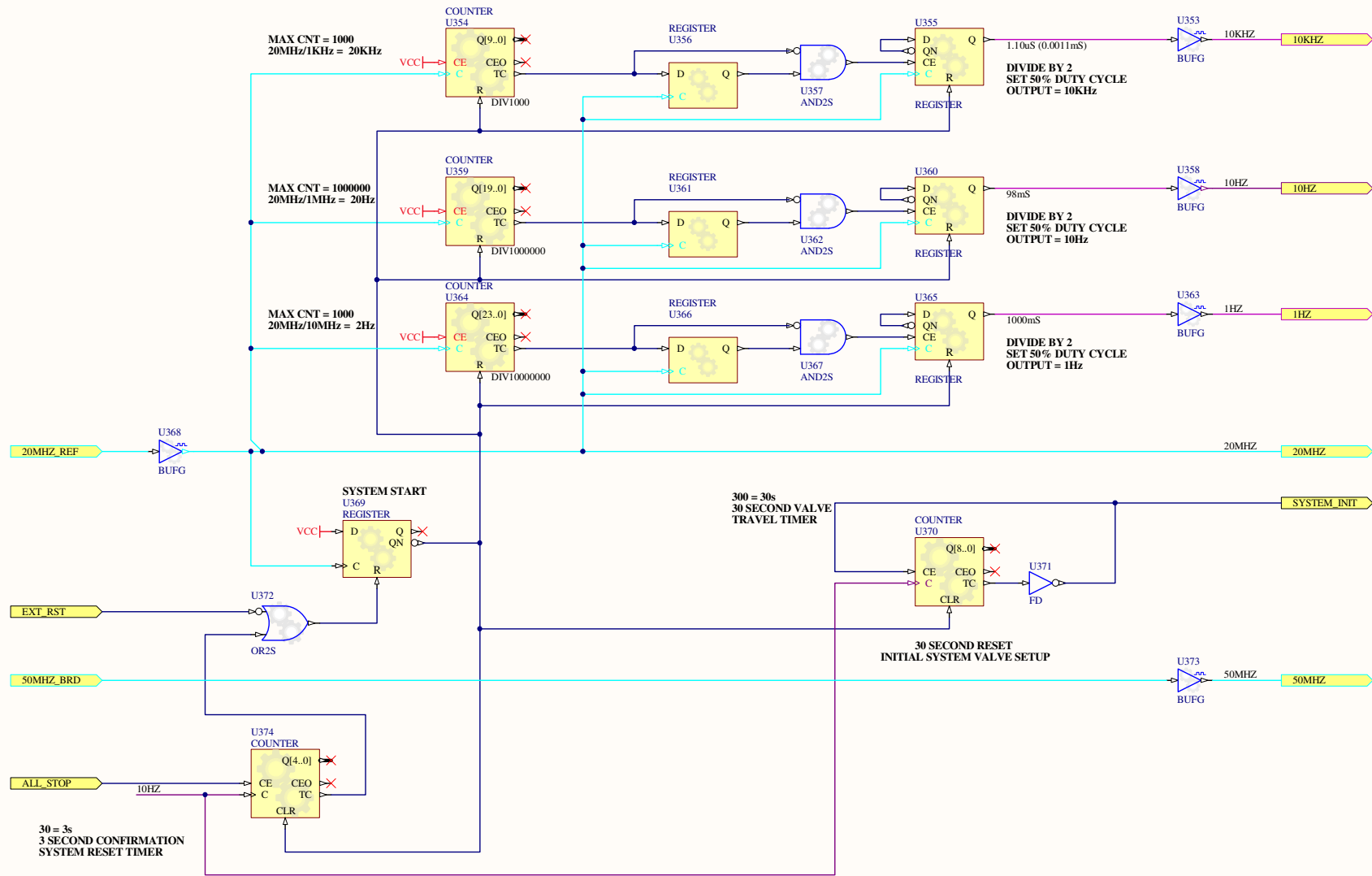

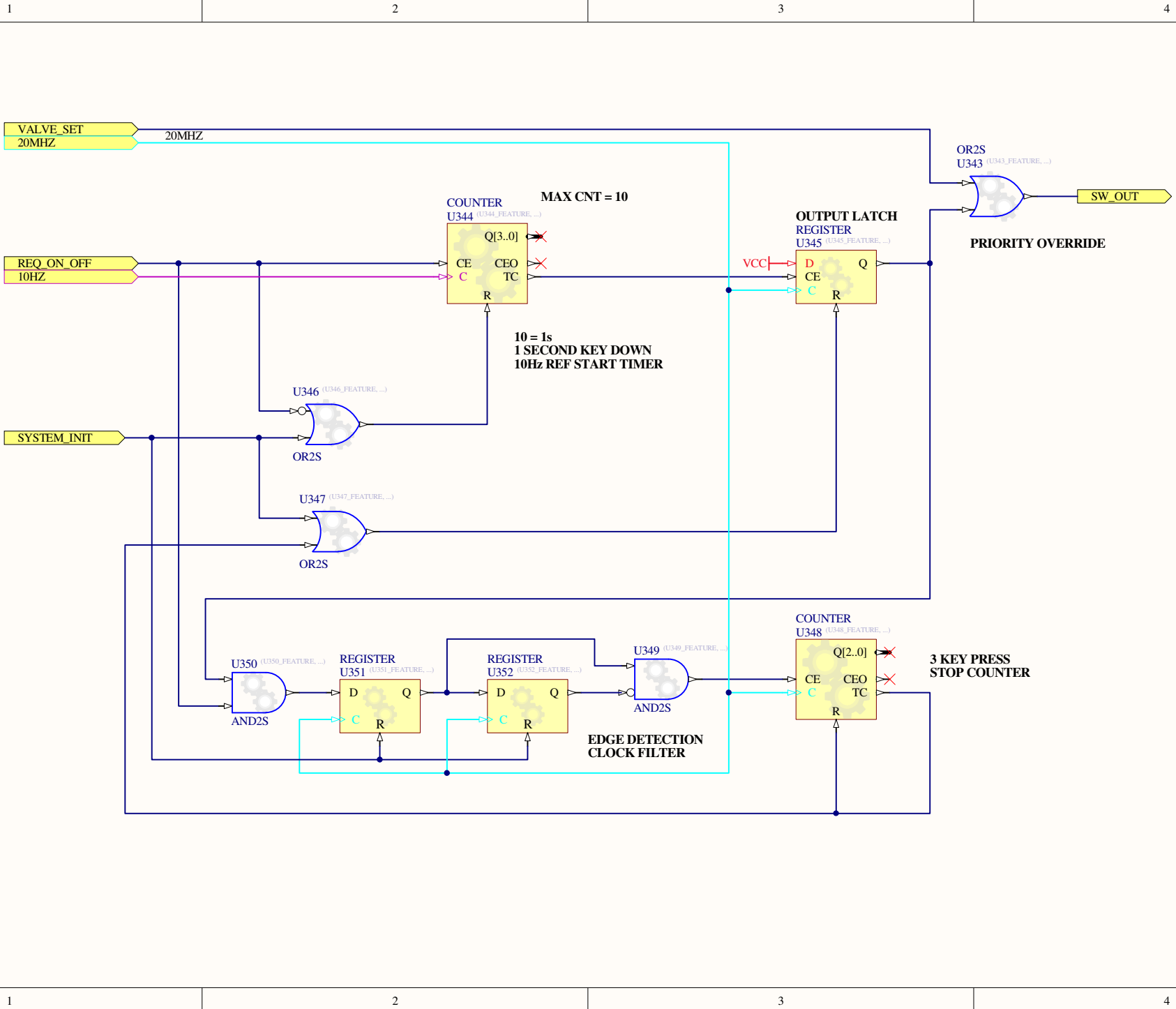

1

2

3

4

A

A

B

B

C

C

D

D

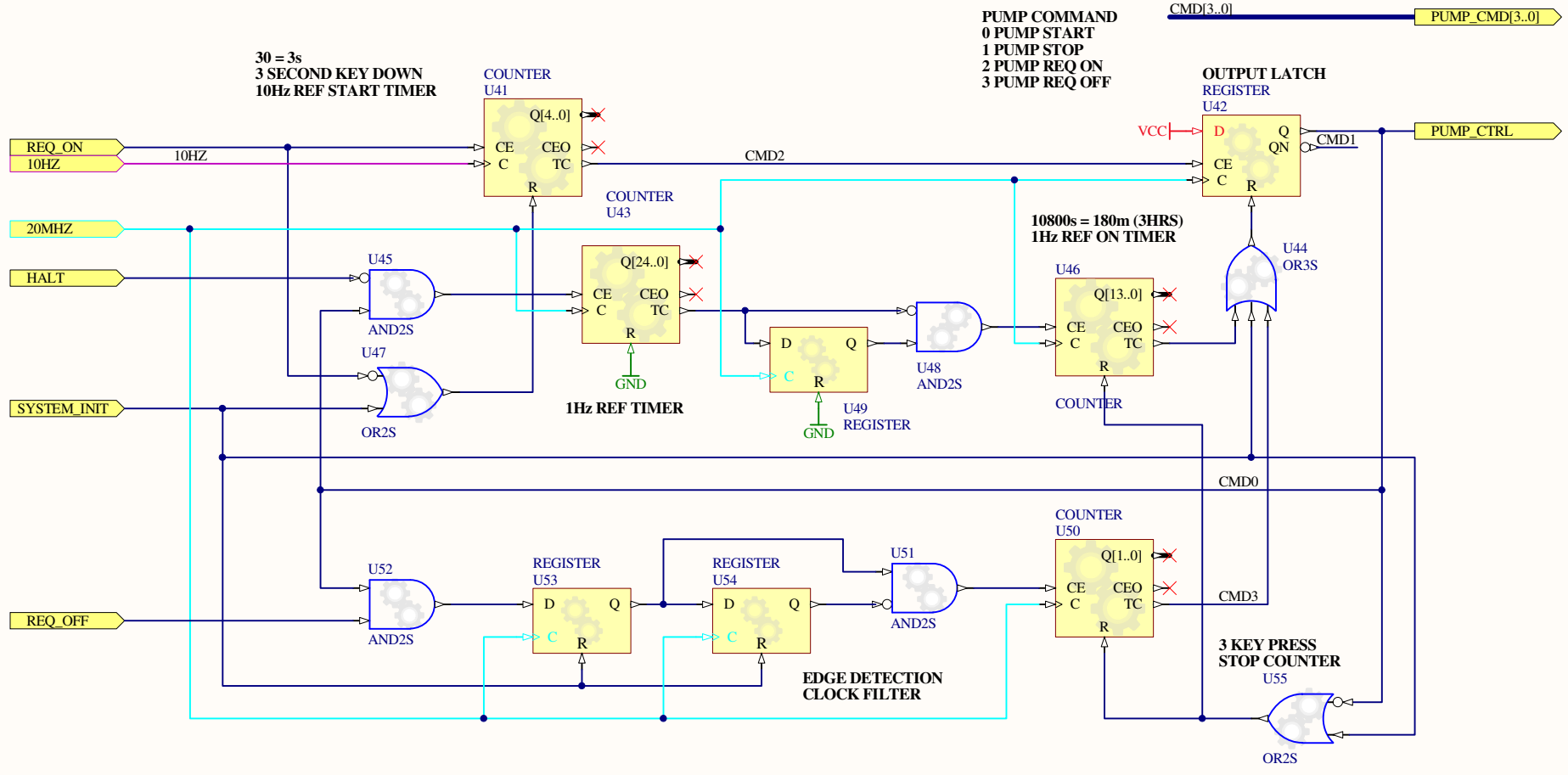

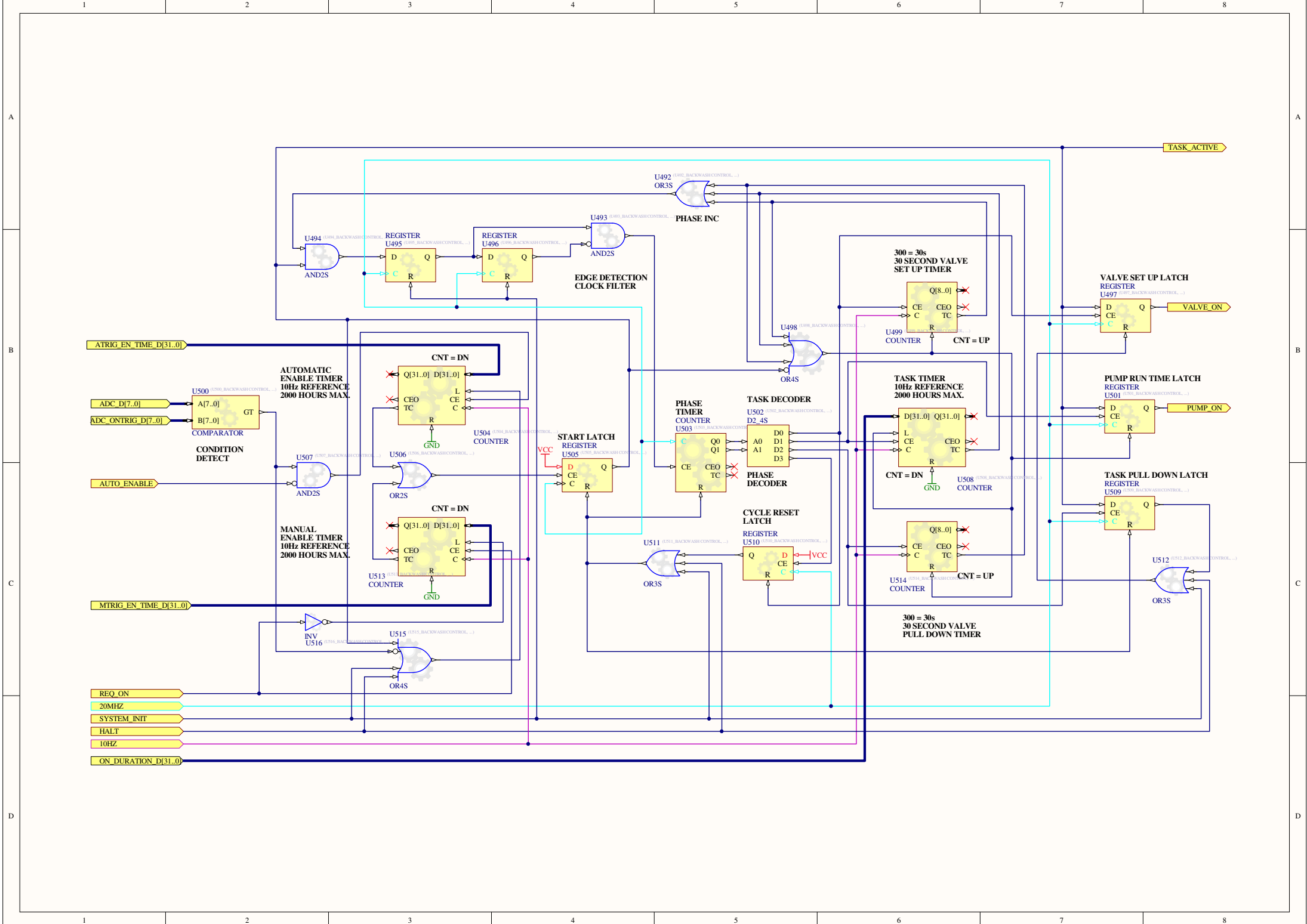

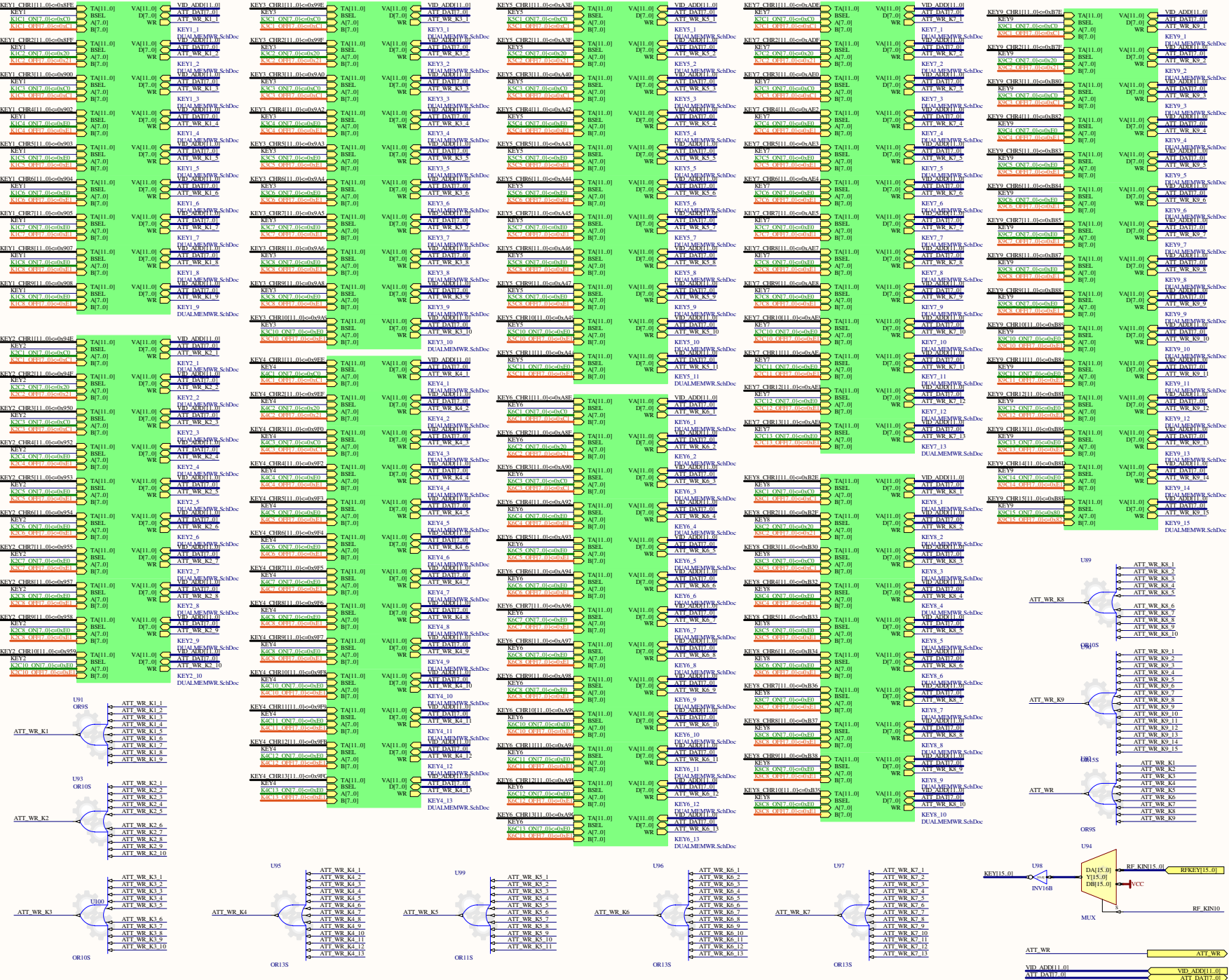

A

B

C

D

A

B

C

D

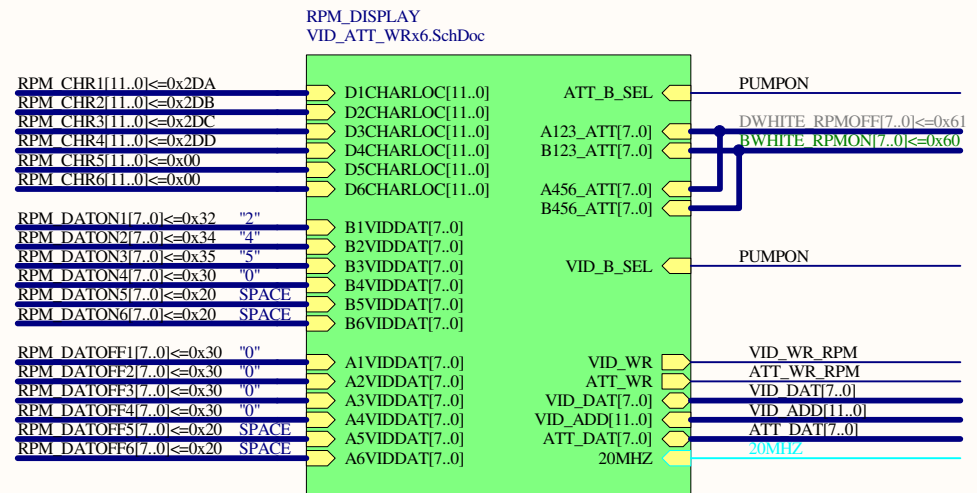
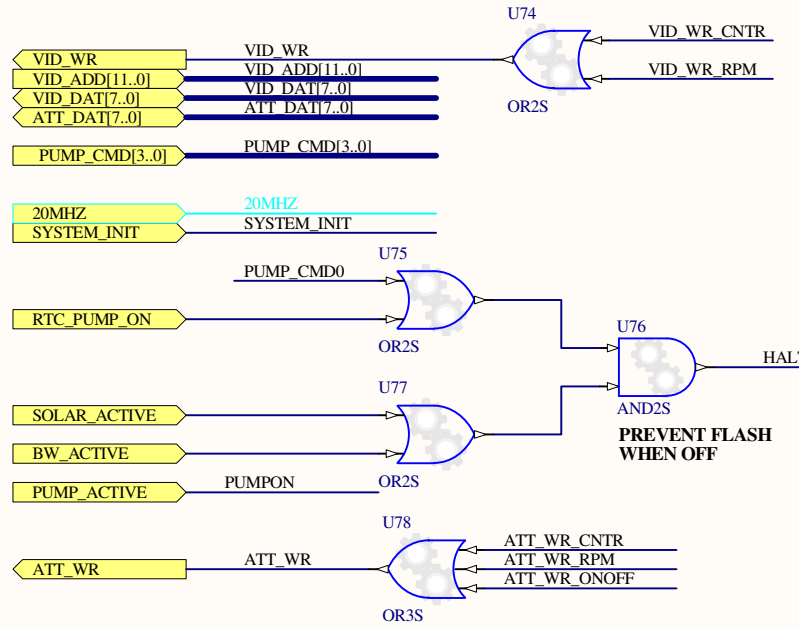
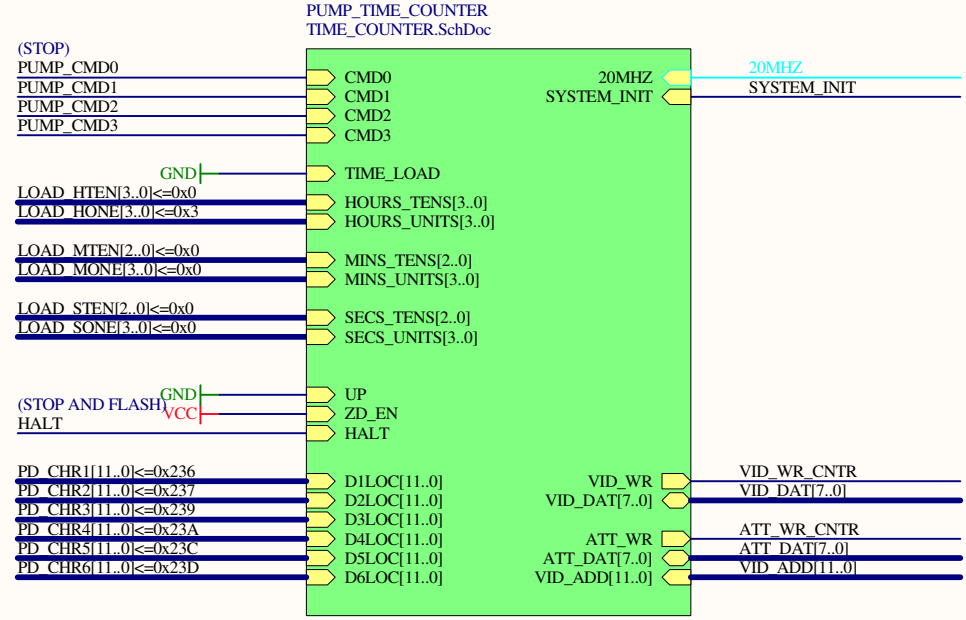
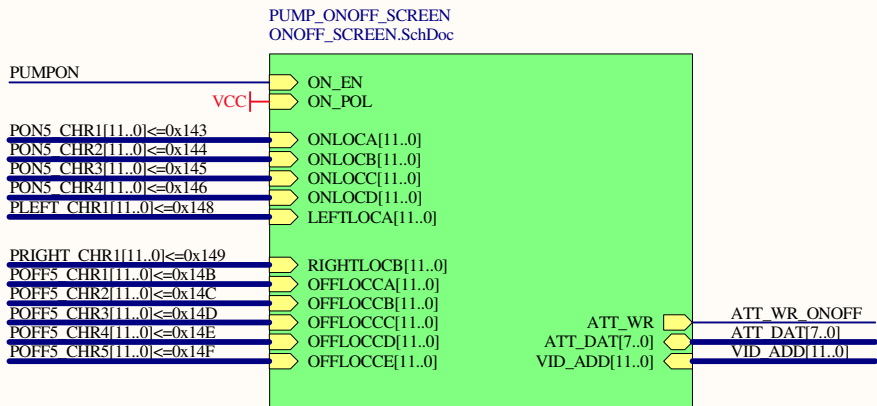

CHLORINATOR_ONOFF_SCREEN
ONOFF_SCREEN.SchDoc

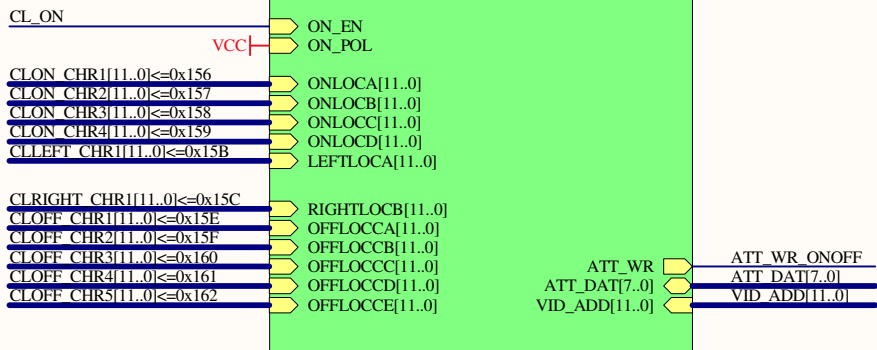

CHLORINATOR_COUNTUP_TIMER
TIME_COUNTER.SchDoc

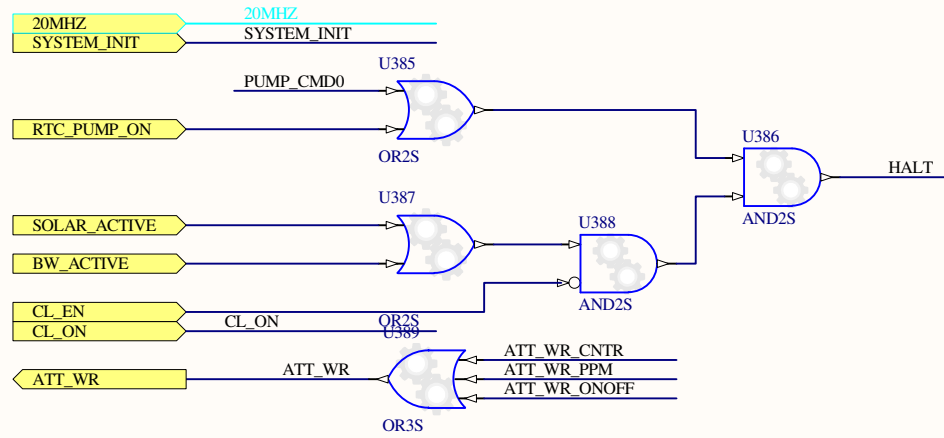
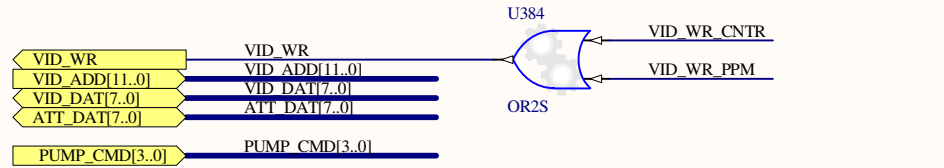
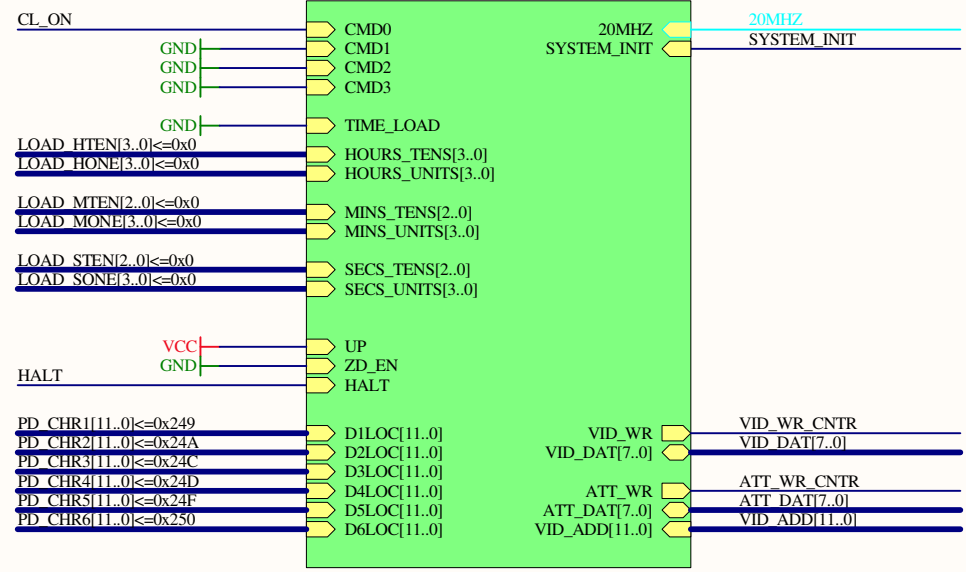

PPM_DISPLAY
VID_ATT_WRx6.SchDoc

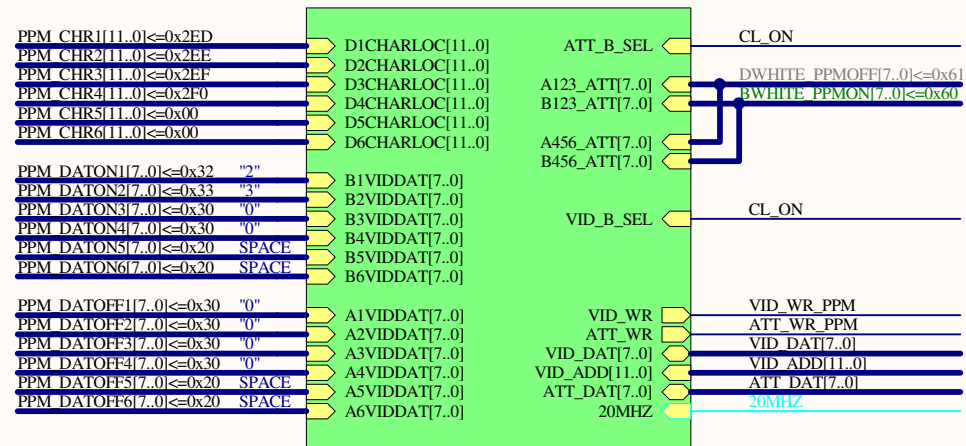

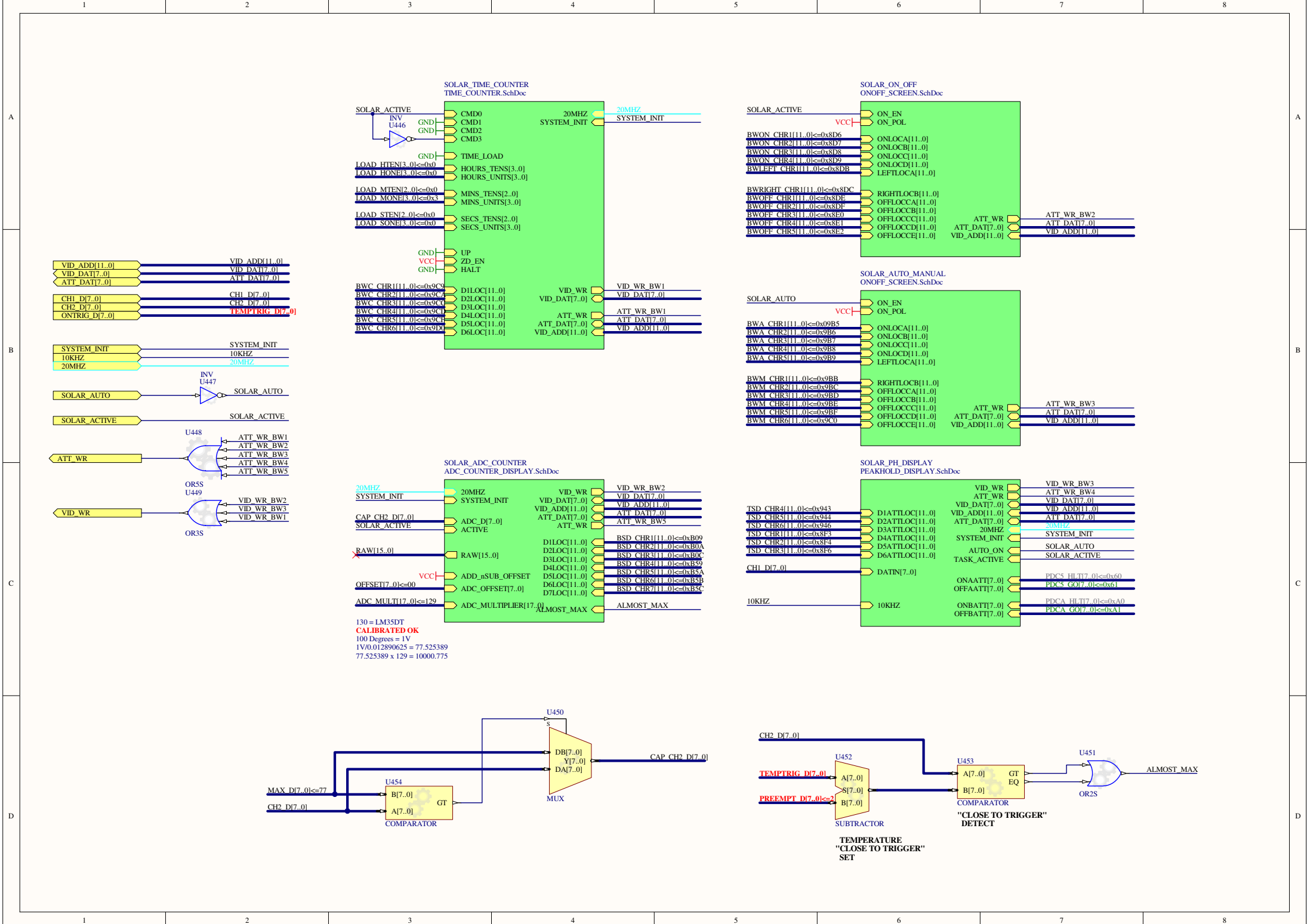

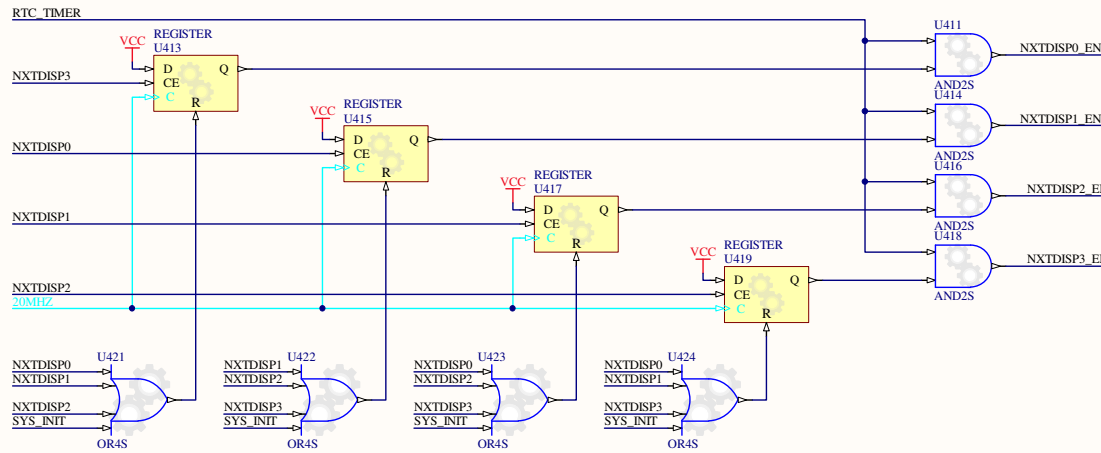
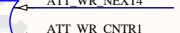
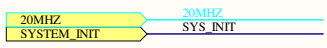
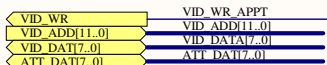
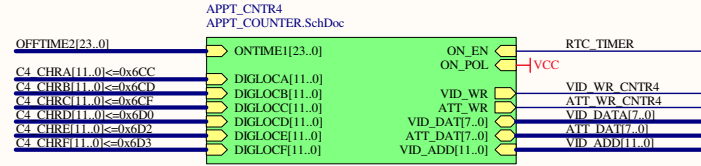
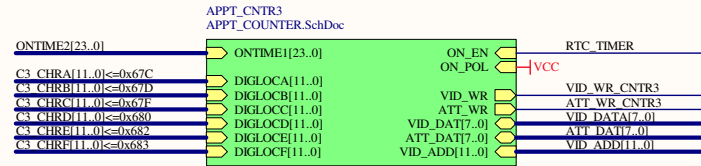
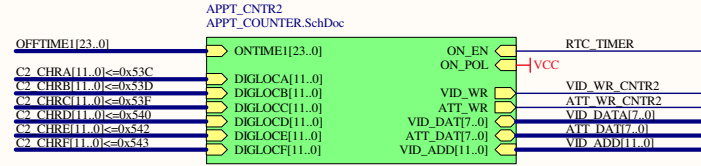
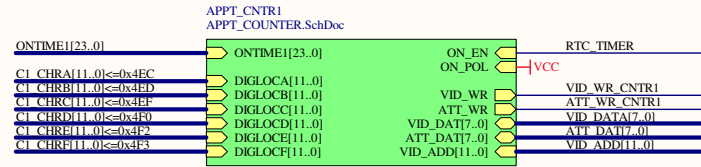
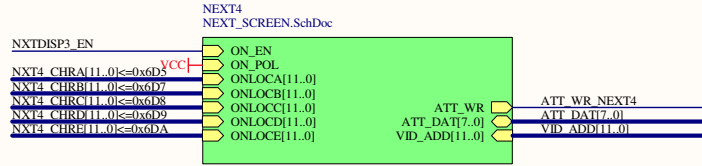
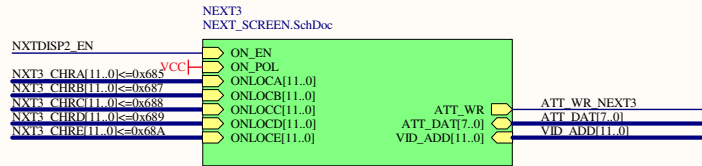
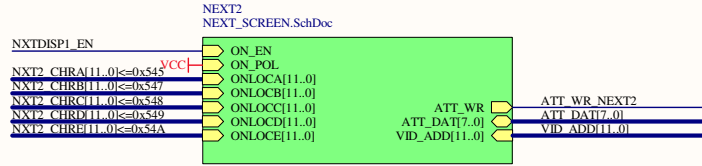
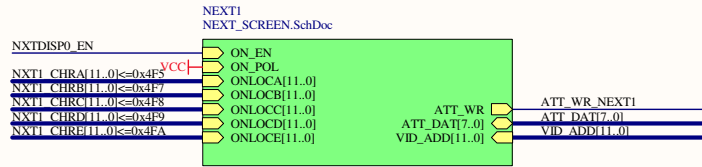

A

B

C

D

A

B

C

D

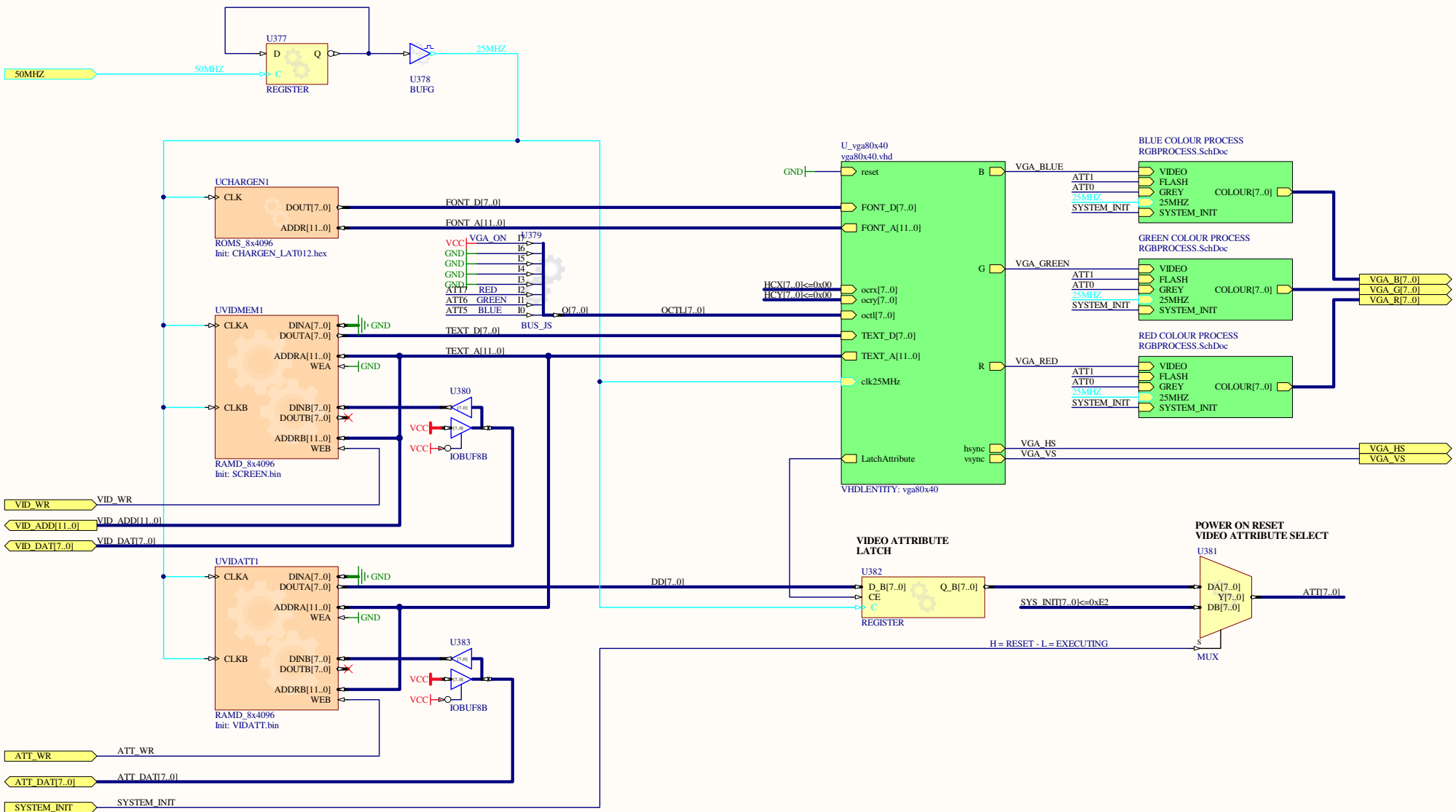

A

B

C

D

A

B

C

D

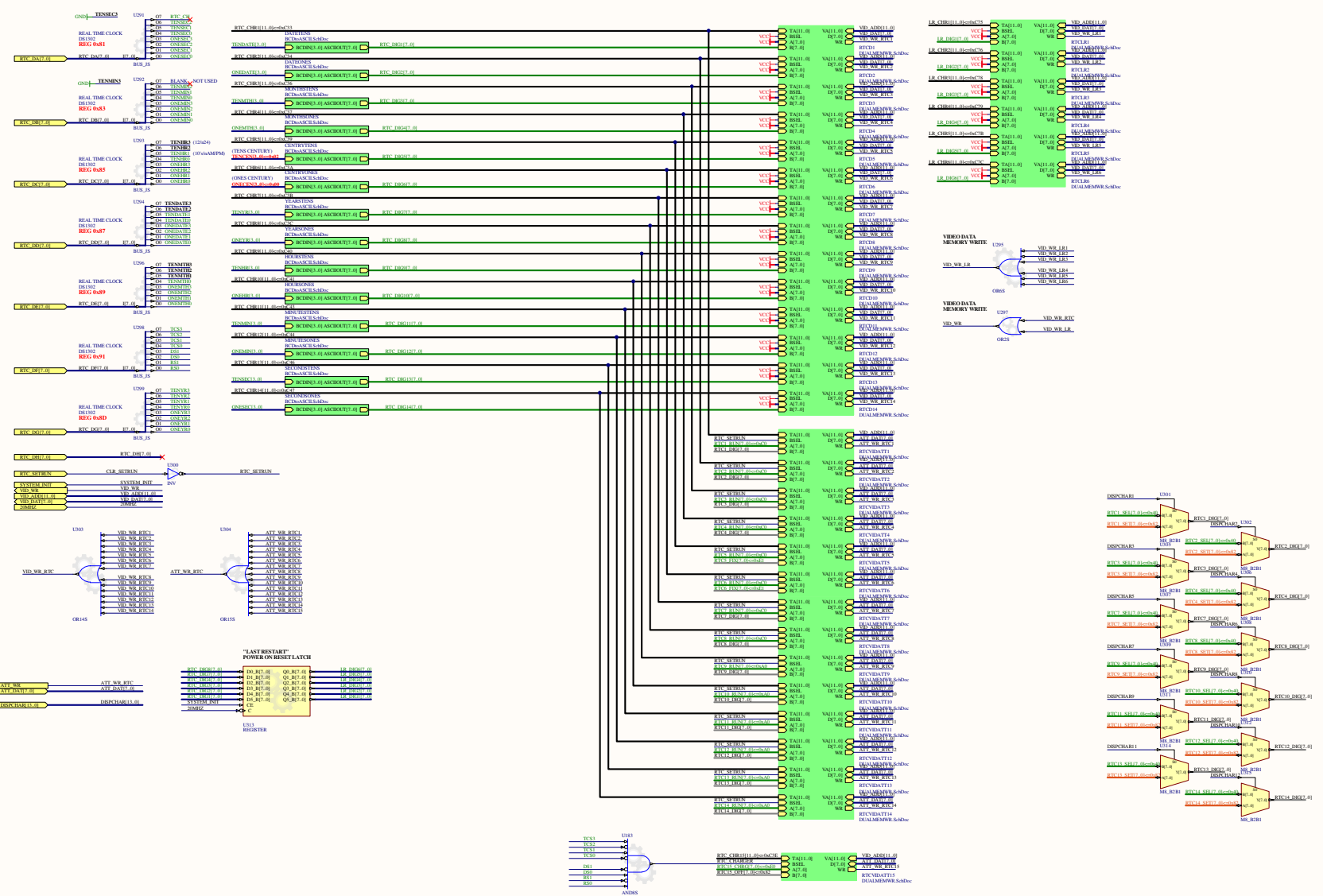

A

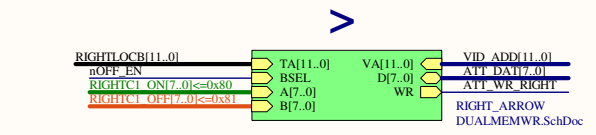
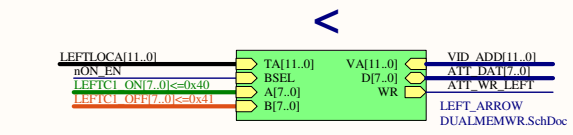
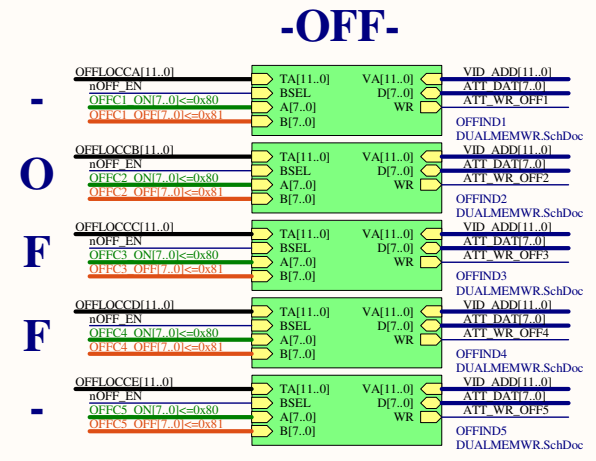
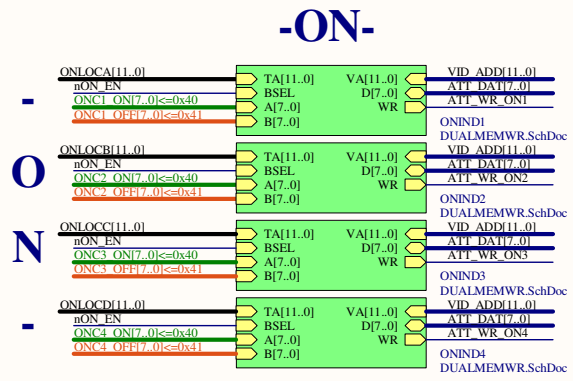

B

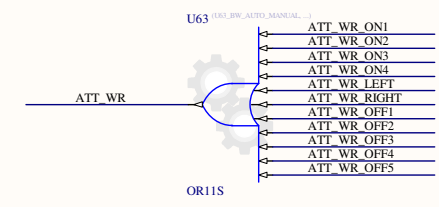
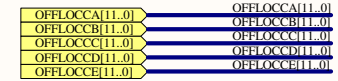
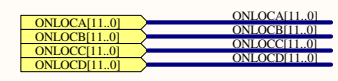
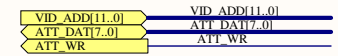
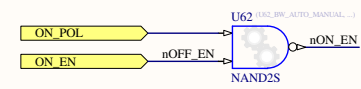

C

D

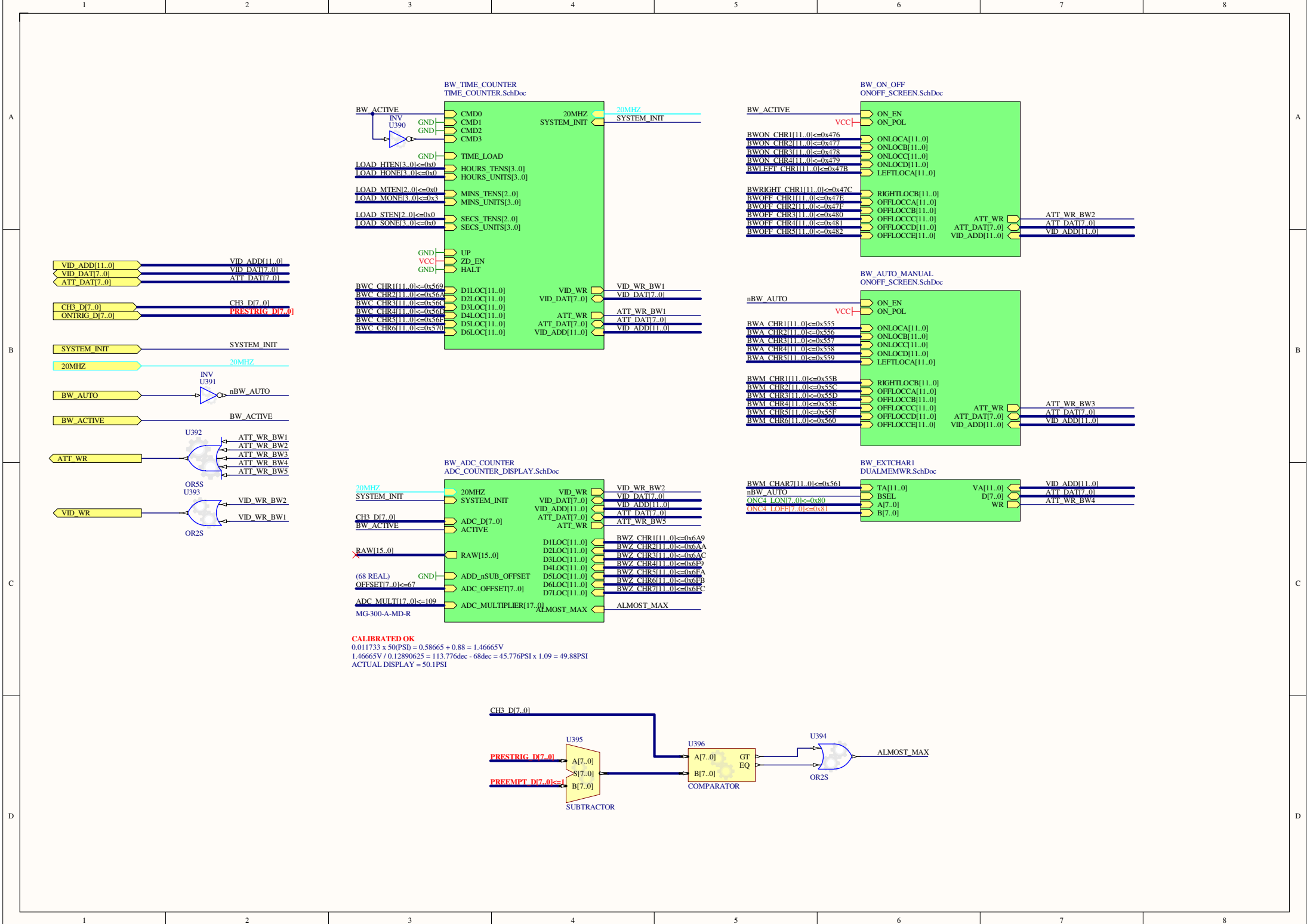

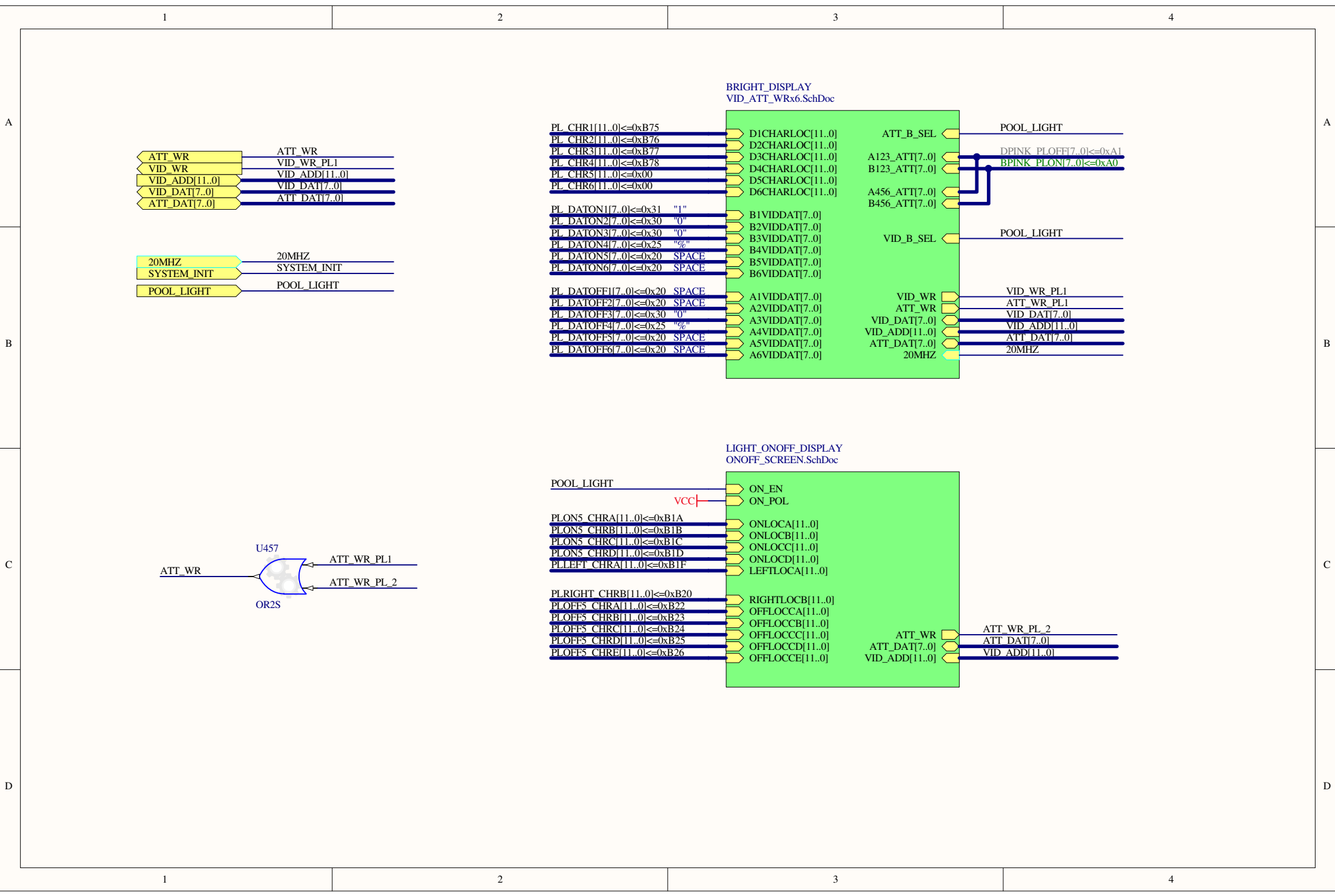

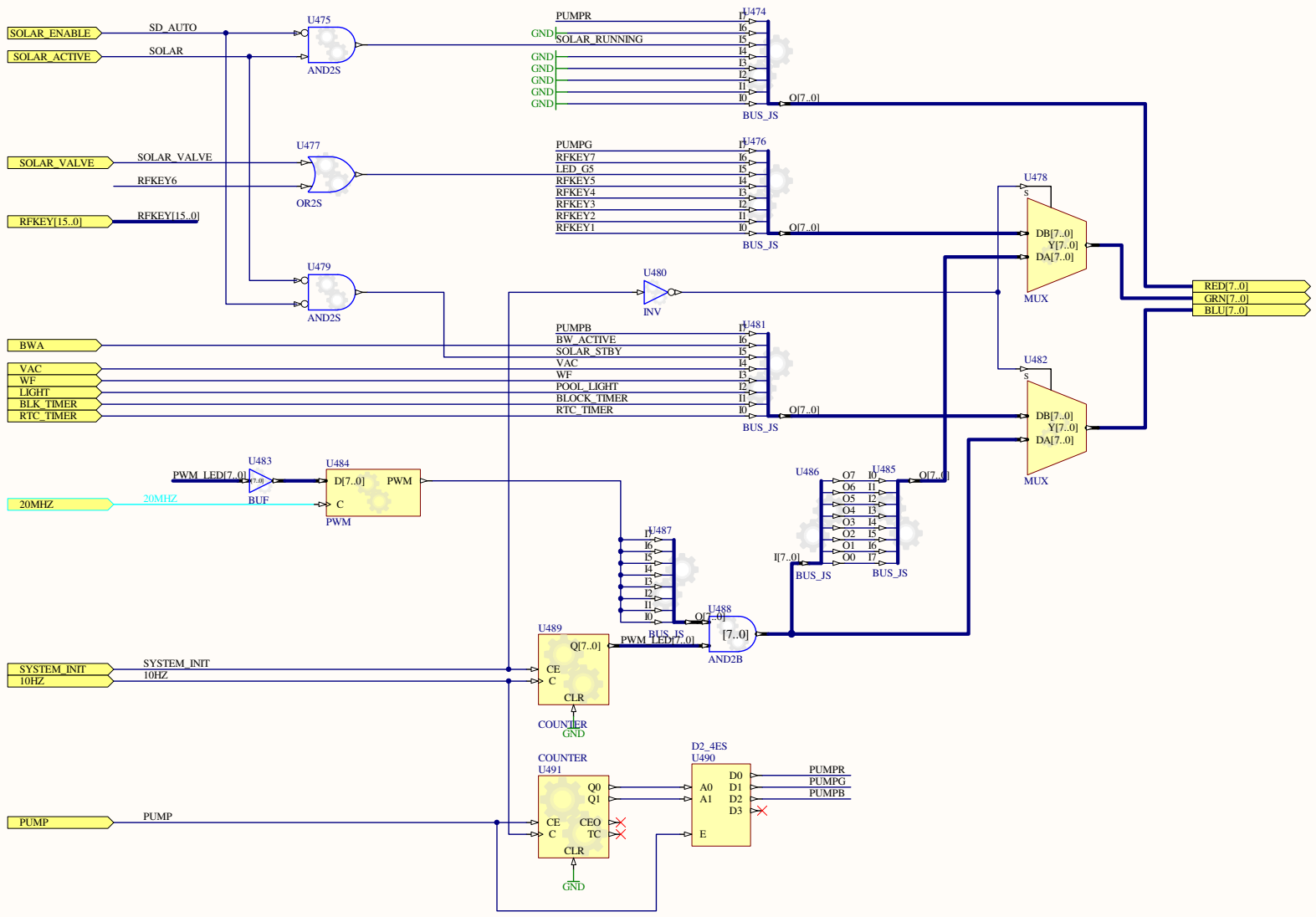

1

2

3

4

A

A

B

B

C

C

D

D

TCP800-12

TCP1000-12

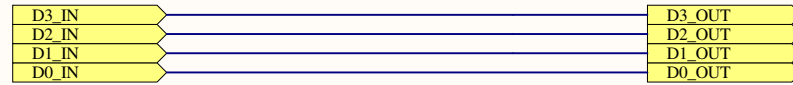

1

2

3

4

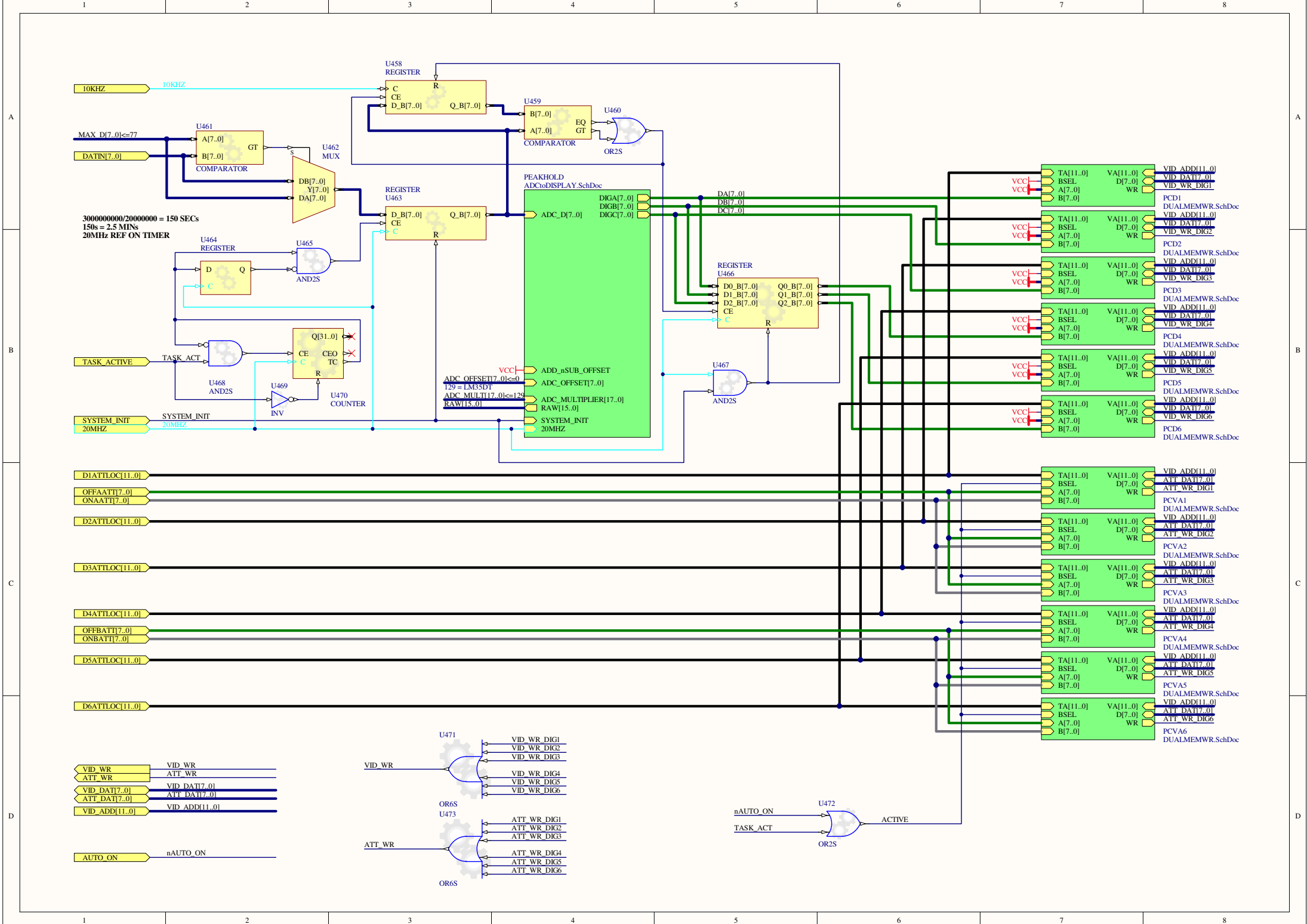

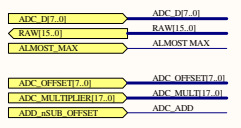
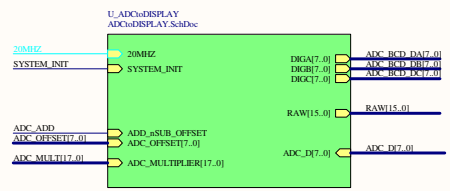
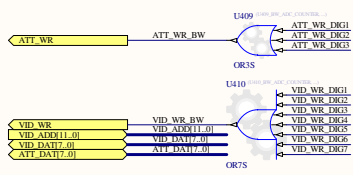
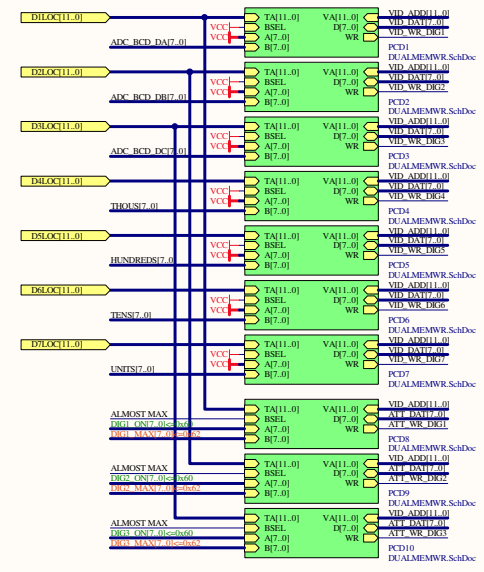
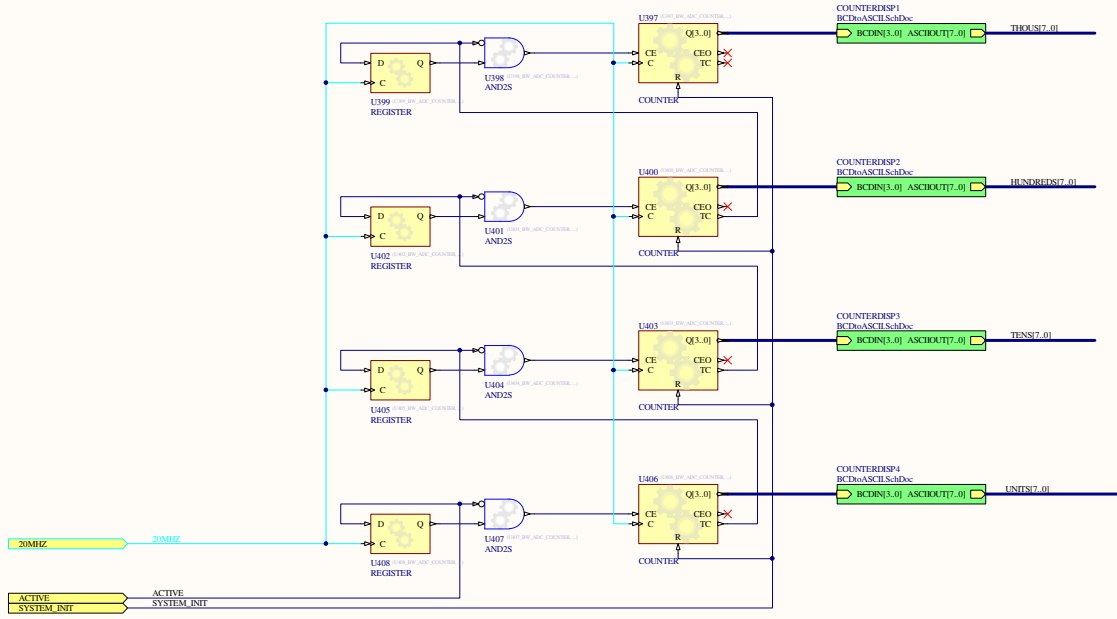

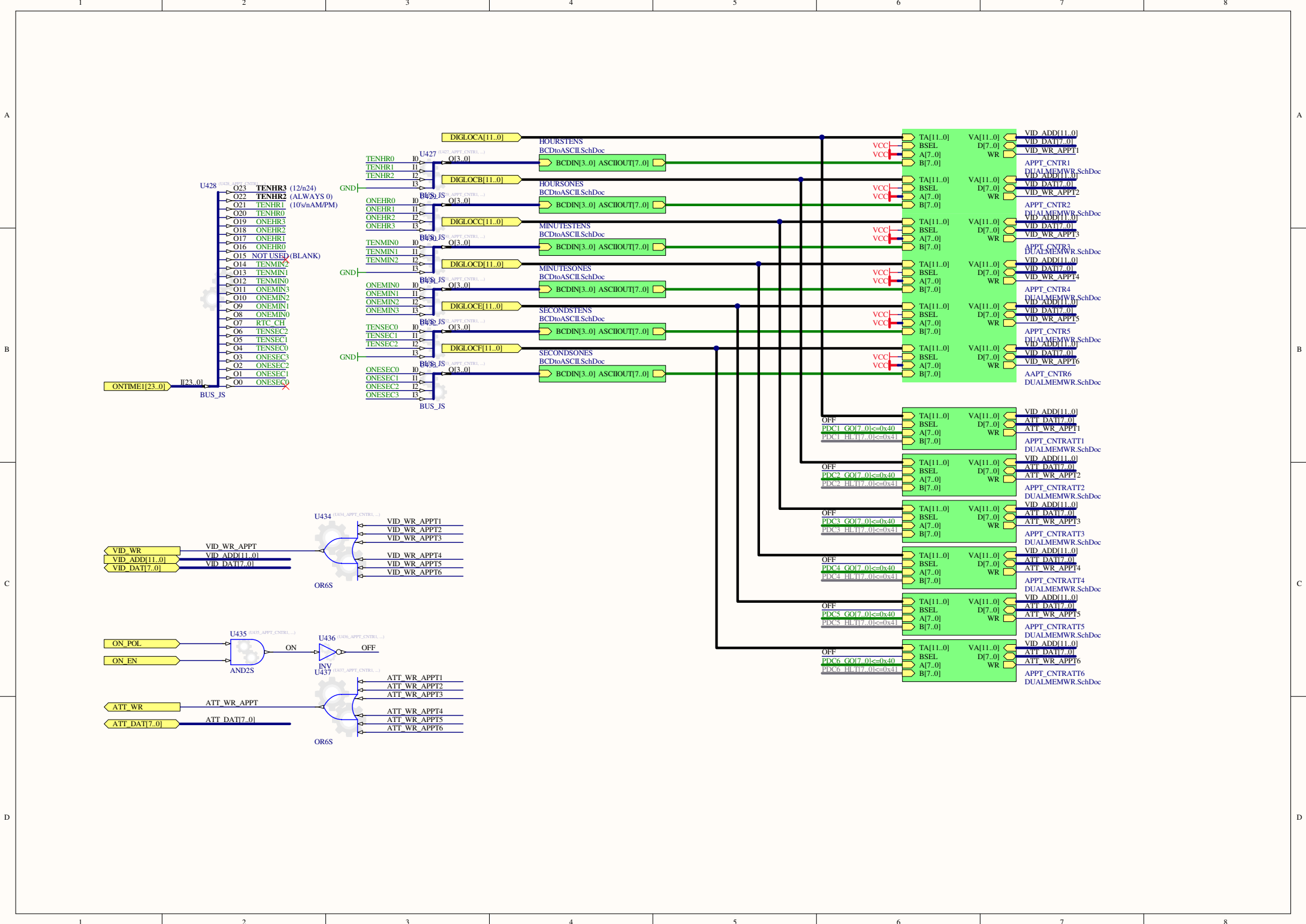

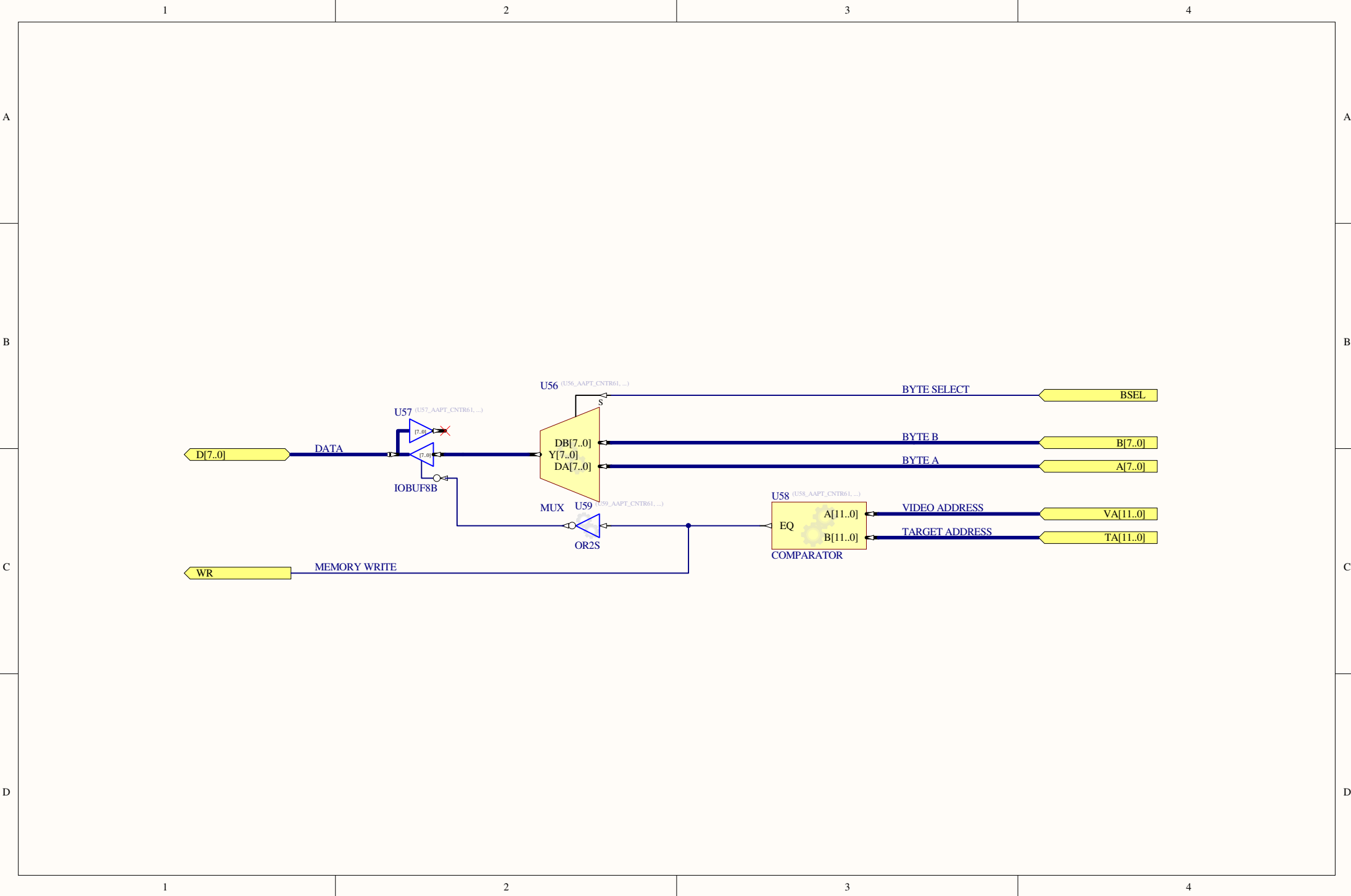

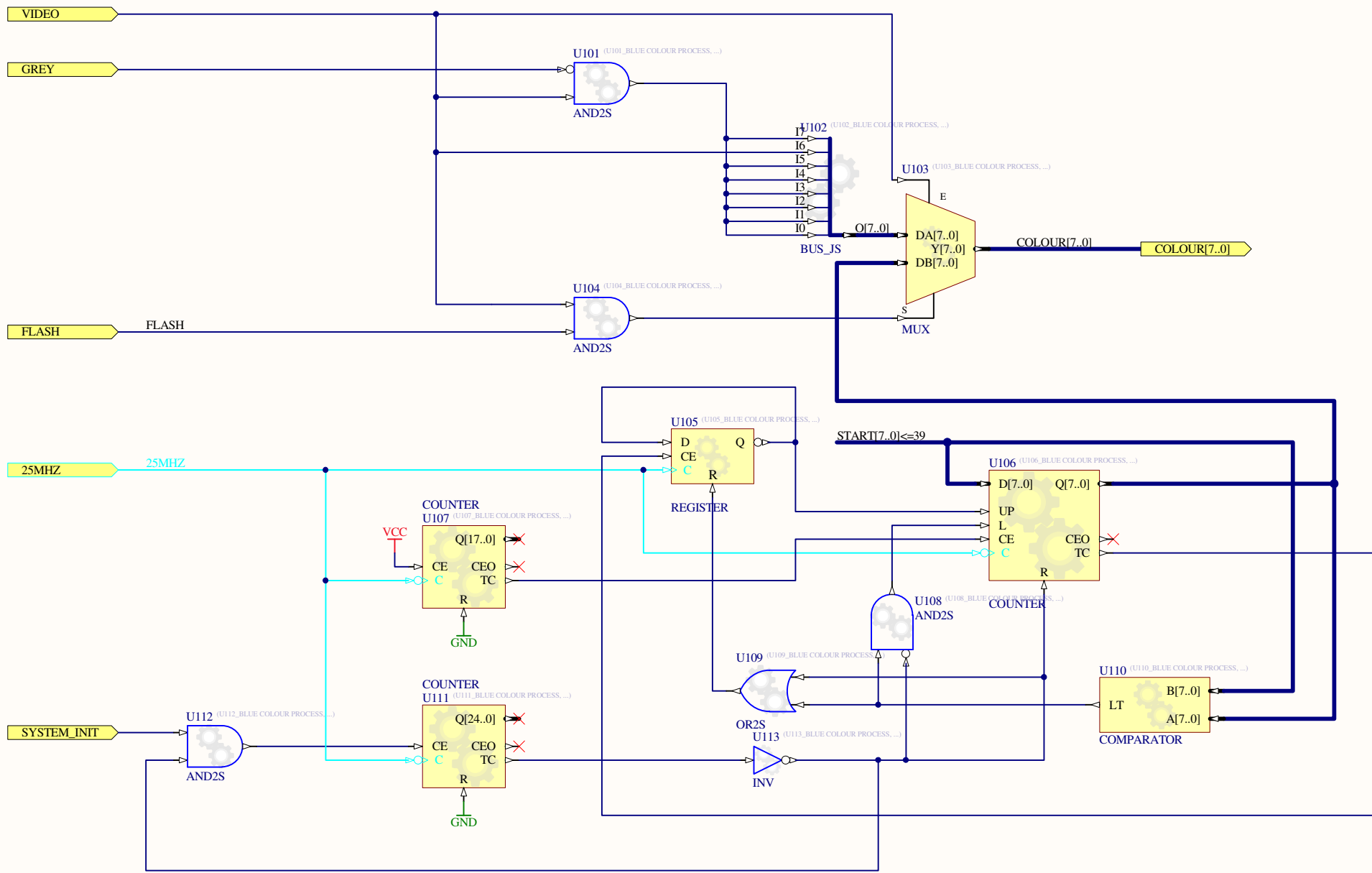

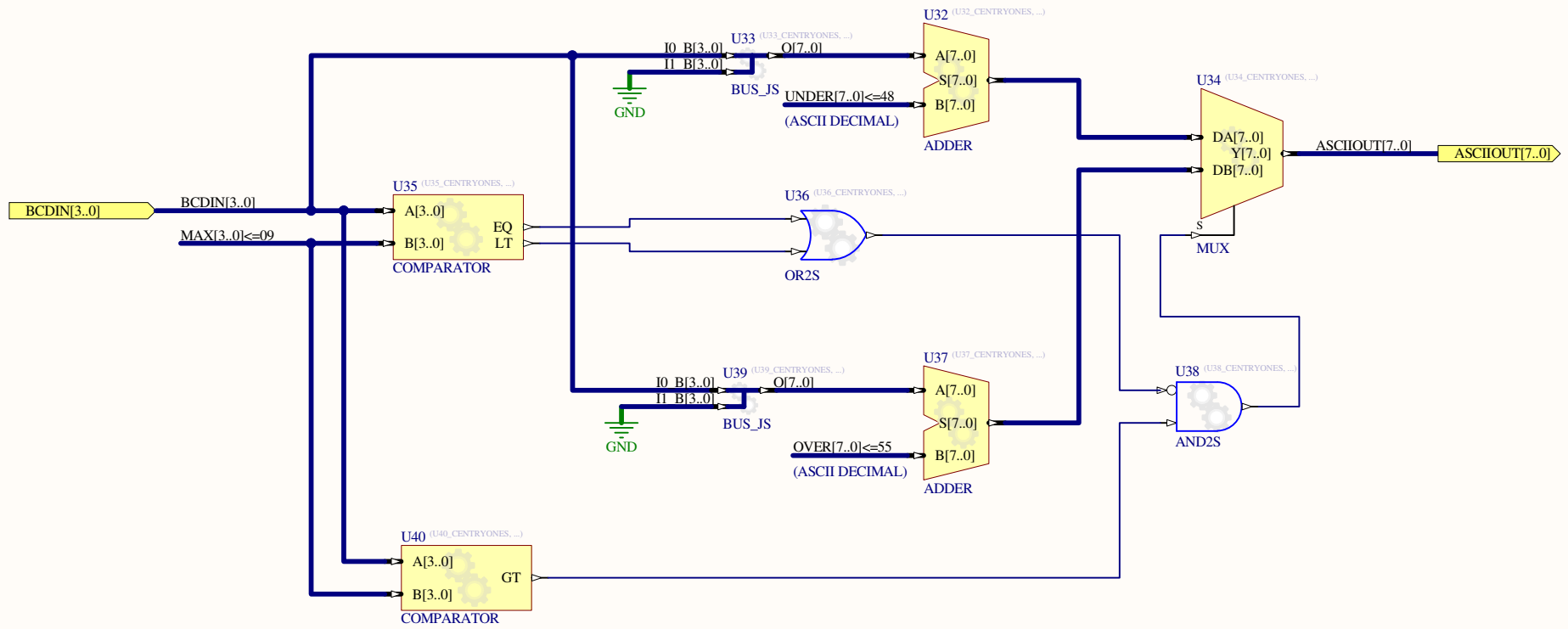

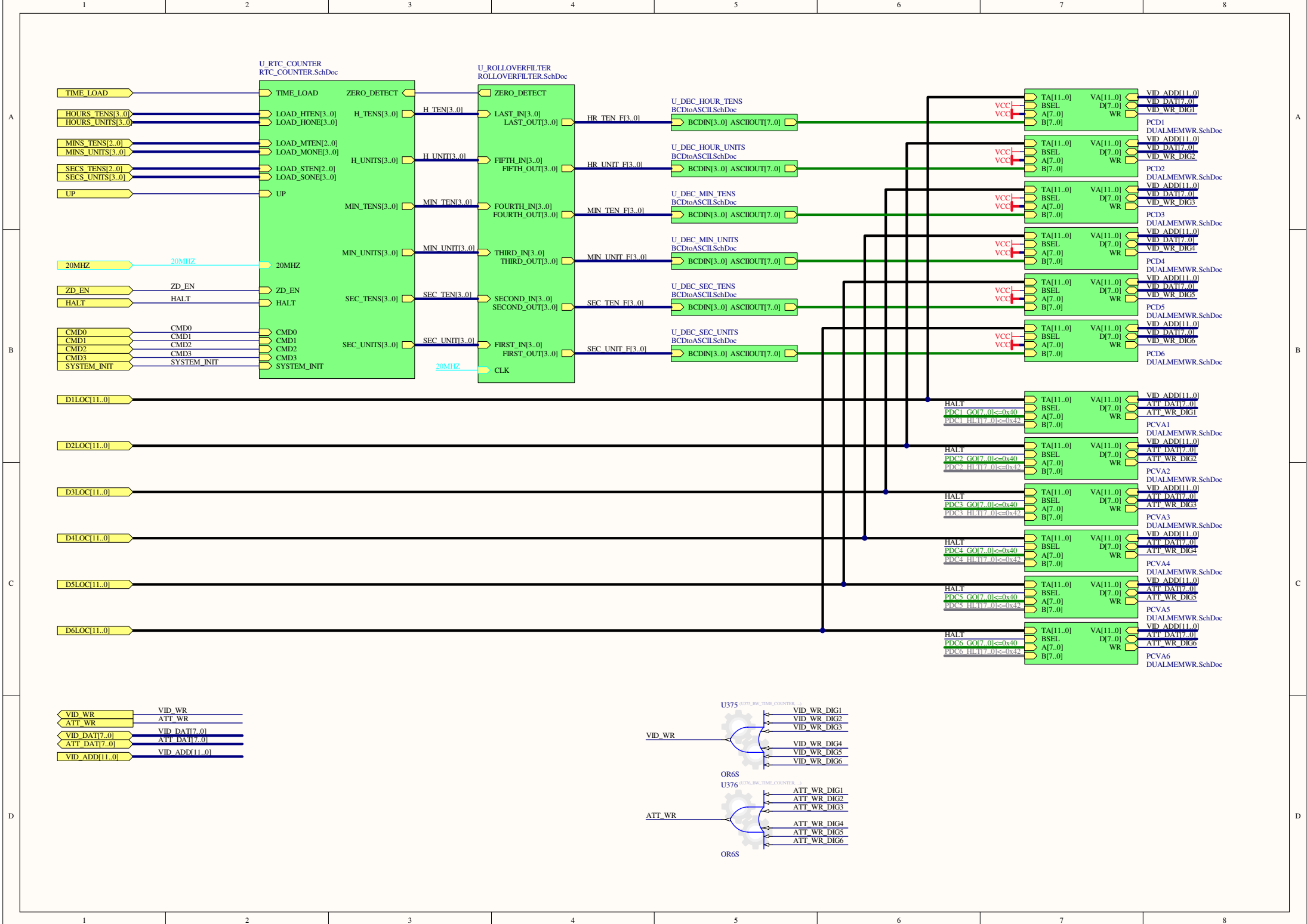

> NEXT

NEXT

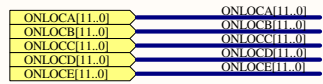
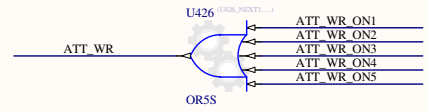
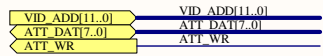
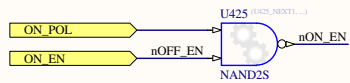
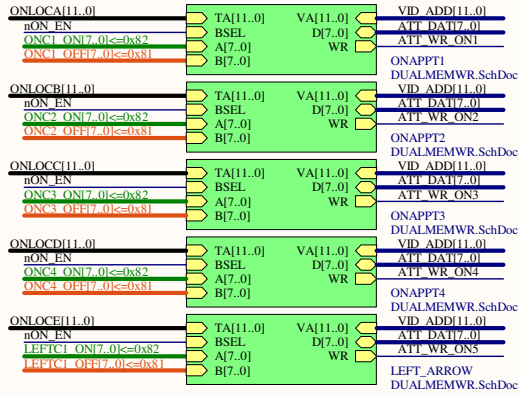

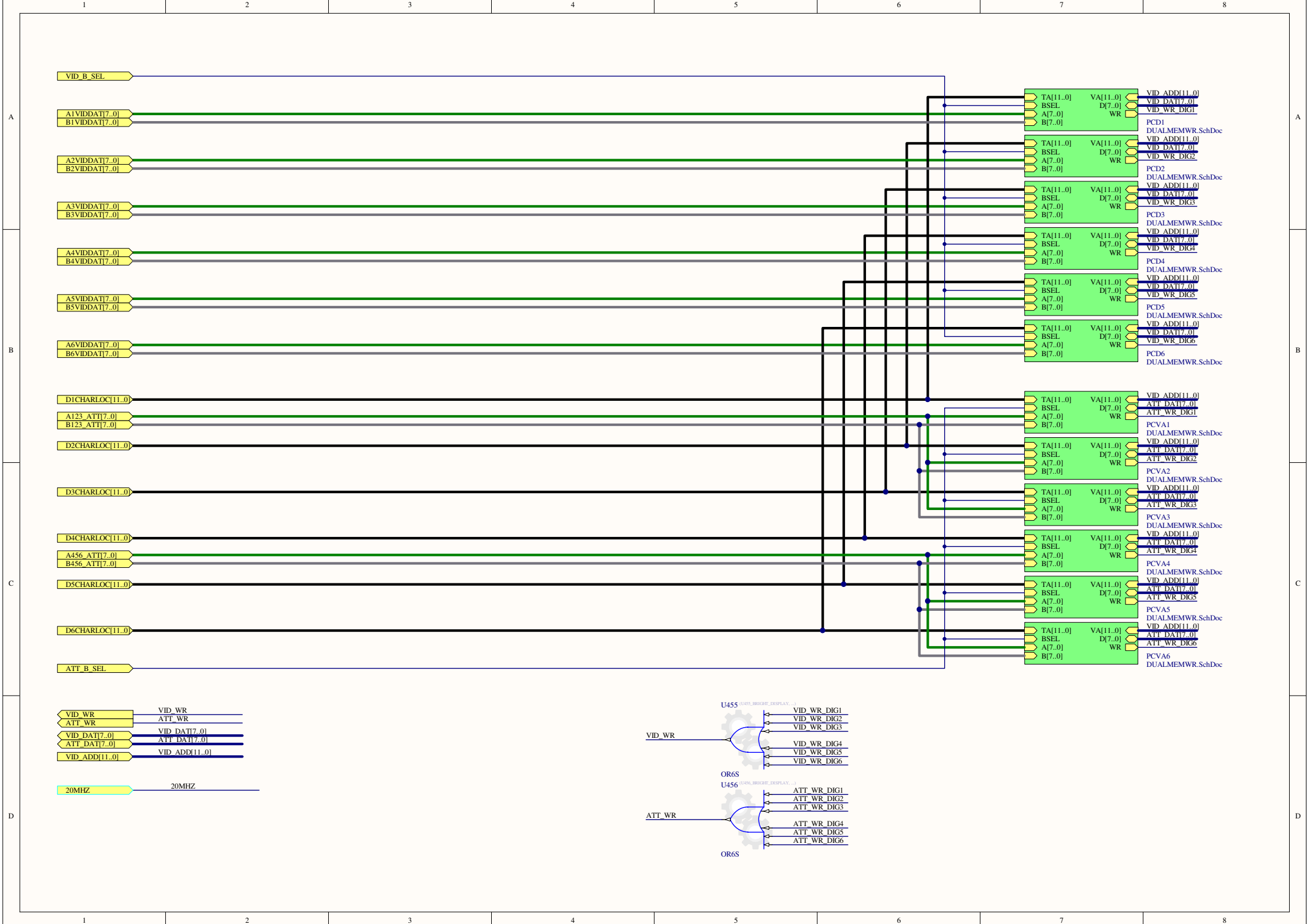

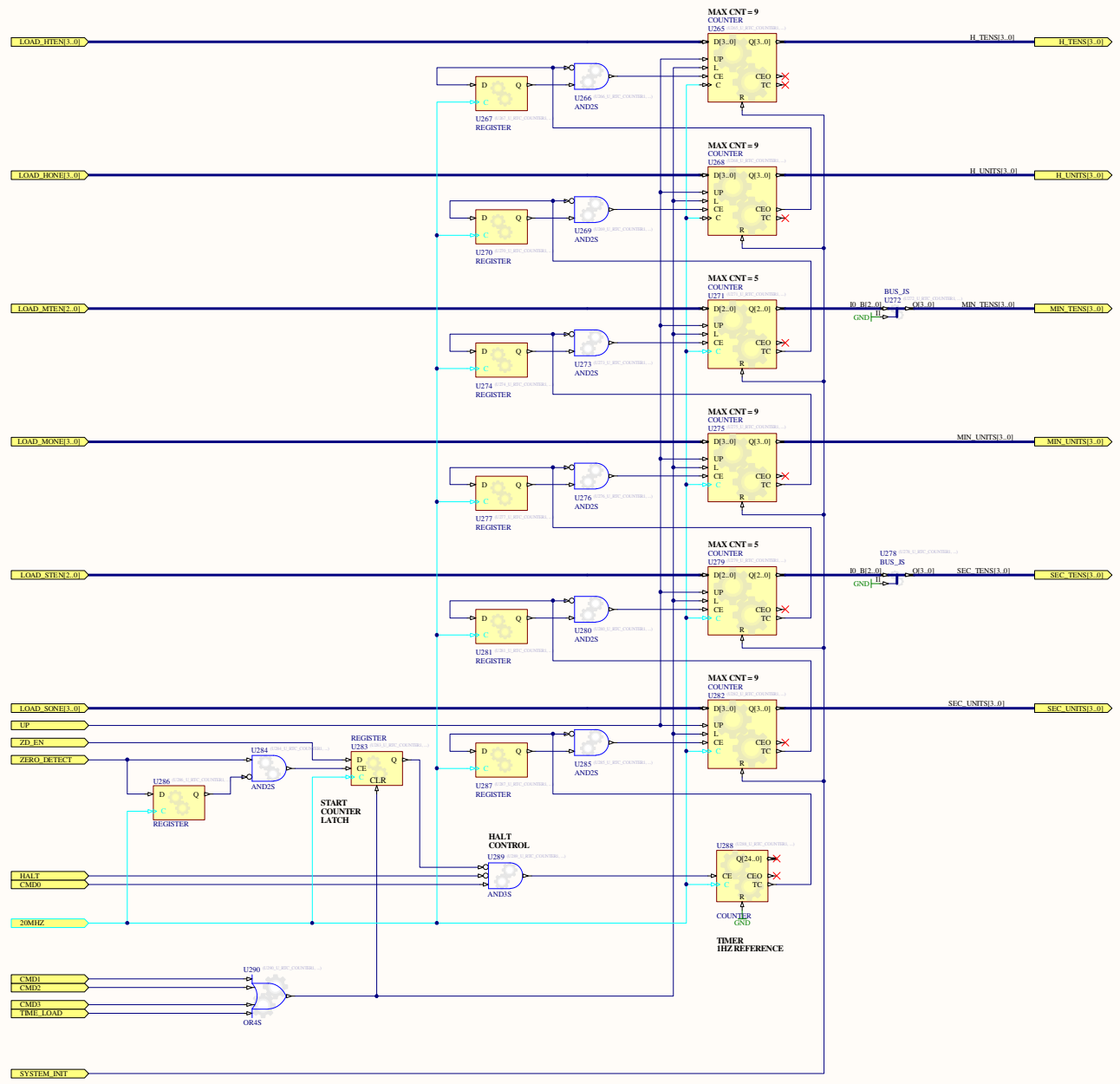

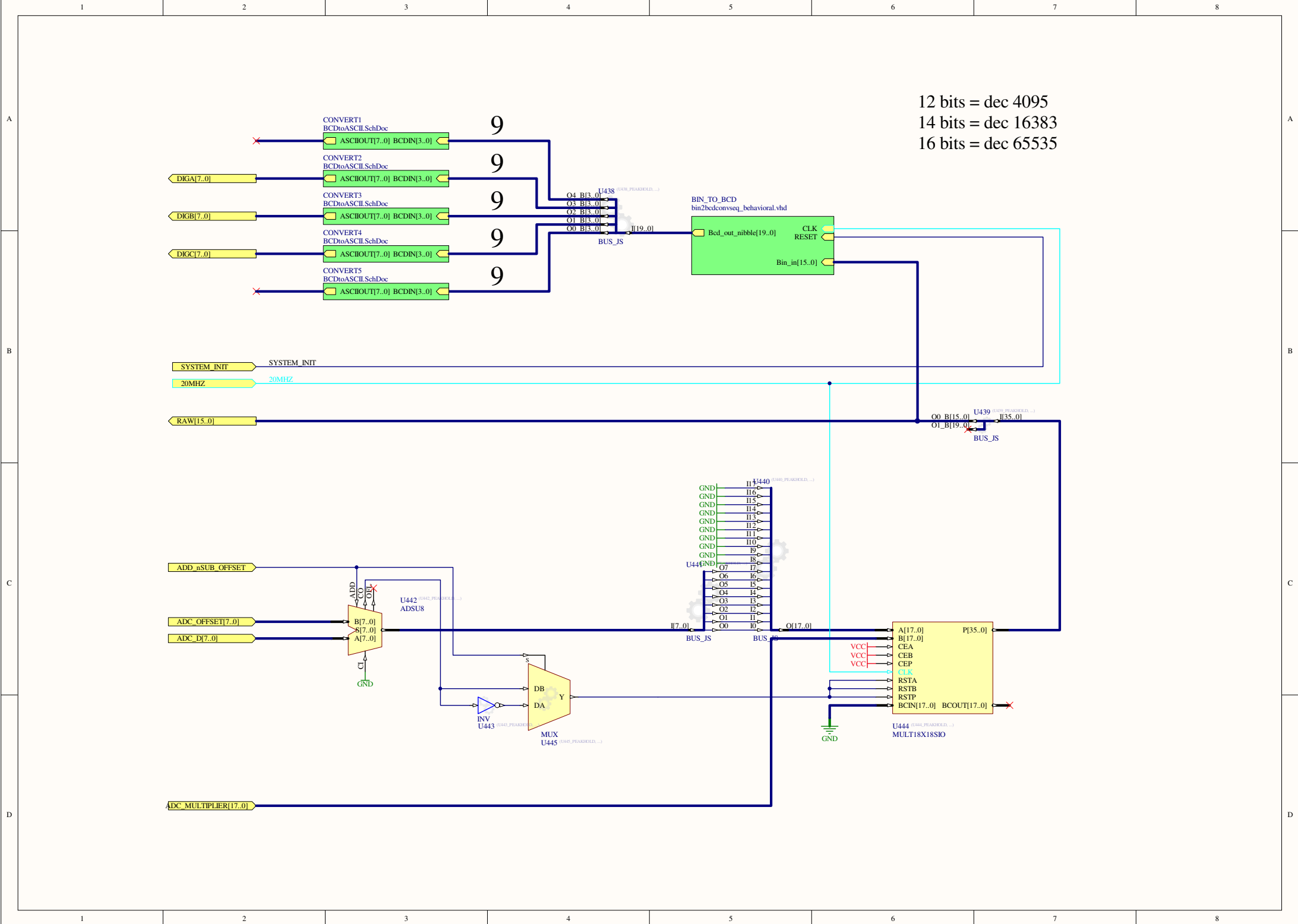

12 bits = dec 4095
 14 bits = dec 16383
 16 bits = dec 65535

A

A

B

B

C

C

D

D

1

2

3

4

5

6

7

8

1

2

3

4

5

6

7

8

